

# Instructions

**95-8549**

UV Flame Detector  
X2200

---



# Table Of Contents

DESCRIPTION .....	1
Outputs .....	1
LED .....	2
Optical Integrity (Oi) .....	2
Communication .....	3
Data Logging / Event Monitoring.....	3
Integral Wiring Compartment .....	3
SIGNAL PROCESSING OPTIONS .....	3
GENERAL APPLICATION INFORMATION .....	4
Response Characteristics .....	4
Welding .....	4
Artificial Lighting .....	4
EMI / RFI Interference.....	4
False Alarm Sources.....	4
Factors Inhibiting Detector Response.....	4
IMPORTANT SAFETY NOTES .....	5
INSTALLATION.....	6
Detector Positioning.....	6
Detector Orientation.....	6
Protection Against Moisture Damage .....	7
Wiring Procedure .....	7
EOL Resistors.....	8
Setting Device Network Addresses (EQP Model Only) .....	13
STARTUP PROCEDURE .....	14
Fire Alarm Test.....	14
TROUBLESHOOTING.....	14
MAINTENANCE.....	15
Cleaning Procedure .....	15
Oi Plate Removal .....	15
Periodic Checkout Procedure .....	15
Clock Battery.....	15
FEATURES.....	16
SPECIFICATIONS .....	16
REPLACEMENT PARTS .....	18
DEVICE REPAIR AND RETURN.....	18
ORDERING INFORMATION .....	19
Accessories.....	19
Replacement Parts .....	19
APPENDIX.....	20

---

**AUTOMATIC**  

---

**UV Flame Detector  
X2200****IMPORTANT**

*Be sure to read and understand the entire instruction manual before installing or operating the flame detection system. Any deviation from the recommendations in this manual may impair system performance and compromise safety.*

**ATTENTION**

*The X2200 includes the Automatic Optical Integrity (oi) feature — a calibrated performance test that is automatically performed once per minute to verify complete detector operation capabilities. **No testing with an external test lamp is required.***

**DESCRIPTION**

The evolution continues with the new X2200 UV Flame Detector. The X2200 meets the most stringent requirements worldwide with advanced detection capabilities and immunity to extraneous sources, combined with a superior mechanical design. The detector is equipped with both automatic and manual **oi** test capability. The detector has Division and Zone explosion-proof ratings and is suitable for use in indoor and outdoor applications.

The standard output configuration includes fire, fault and auxiliary relays. Output options include:

- 4 to 20 mA output (in addition to the three relays)
- Pulse output for compatibility with existing controller based systems (with fire and fault relays)
- Eagle Quantum Premier (EQP) compatible model (no analog or relay outputs).

\***oi** is Detector Electronics' Trademark for its patented Optical Integrity Systems, U.S. Patent 3,952,196, United Kingdom Patent 1,534,969, Canada Patent 1,059,598.

A multi-color LED on the detector faceplate indicates detector status condition.

The X2200 housing is available in copper-free aluminum or stainless steel, both with NEMA 4X and IP66 rating.

**OUTPUTS****Relays**

The standard detector is furnished with fire, fault and auxiliary relays. All three relays are rated 5 amperes at 30 VDC.

The Fire Alarm relay has redundant terminals and normally open / normally closed contacts, normally de-energized operation, and latching or non-latching operation.

The Fault relay has redundant terminals and normally open contacts, normally energized operation, and latching or non-latching operation.

The Auxiliary relay has normally open / normally closed contacts, and is configurable for energized or de-energized operation, and latching or non-latching operation.

#### 4 to 20 mA Output

A 4 to 20 mA output is available as an option (in addition to the three relays). This option provides a 4 to 20 mA dc current output for transmitting detector status information to other devices. The circuit can be wired in either an isolated or non-isolated configuration and can drive a maximum loop resistance of 500 ohms from 18 to 19.9 volts dc and 600 ohms from 20 to 30 volts dc. Table 1 indicates the detector status conditions represented by the various current levels. The output is calibrated at the factory, with no need for field calibration.

#### NOTE

*The output of the 4 to 20 mA current loop is not monitored by the fault detection circuitry of the X2200. Therefore, an open circuit on the loop will not cause the fault relay to change state or the detector status LED to indicate a fault. The status of the LED always follows the status of the relays.*

An alarm condition will normally over-ride a fault condition, unless the nature of the fault condition impairs the ability of the detector to generate or maintain an alarm output, i.e. loss of operating power.

Table 1—Detector Status Conditions Indicated by Current Level

Current Level (±0.3 mA)	Detector Status
0 mA	General Fault
1 mA	Internal Power Supply Fault
2 mA	O <sub>i</sub> Fault
4 mA	Normal Operation
16 mA	Pre-Alarm
20 mA	Fire Alarm

#### LON/SLC Output

The EQP model is designed for use exclusively with the Det-Tronics Eagle Quantum Premier system. The detector communicates with the system controller over a digital communication network or LON/SLC (Local Operating Network / Signalling Line Circuit). The LON/SLC is a fault tolerant, two wire digital communication network arranged in a loop configuration. Analog and relay outputs are not available on this model.

Table 2—Detector Status Indicator

Detector Status	LED Indicator
Power On/Normal Auto O <sub>i</sub> (no fault or fire alarm)	Green
Power On/Normal Man O <sub>i</sub>	Green, flashing on for 0.5 sec. every 5 sec.
Fault	Amber
Pre-Alarm/Background UV	Red, flashing on for 500 ms. and off for 500 ms.
Fire (Alarm)	Steady Red
On Power-Up, The LED Flashes in Sequence as Follows, Indicating Sensitivity and Signal Processing Status	
Low UV Sensitivity Medium UV Sensitivity High UV Sensitivity Very High UV Sensitivity	One Red Flash Two Red Flashes Three Red Flashes Four Red Flashes
Stand. UV Signal Process. Arc Rej. UV Signal Process.	One Amber Flash Two Amber Flashes

#### LED

A tricolor LED on the detector faceplate indicates normal, fire alarm and fault conditions. Table 2 indicates the condition of the LED for each status.

#### OPTICAL INTEGRITY (O<sub>i</sub>)

##### Automatic o<sub>i</sub>

The X2200 includes the Automatic Optical Integrity (**o<sub>i</sub>**) feature — a calibrated performance test that is automatically performed once per minute to verify complete detector operation capabilities. No testing with an external test lamp is required. The detector automatically performs the same test that a maintenance person with a test lamp would perform — once every minute, 60 times per hour. However, a successful automatic **o<sub>i</sub>** test does not produce an alarm condition.

The X2200 signals a fault condition when less than half of the detection range remains. This is indicated by the Fault relay and is evident by the amber color of the LED on the face of the detector. See the "Troubleshooting" section for further information.

##### Magnetic o<sub>i</sub> / Manual o<sub>i</sub>

The detector also incorporates both magnetic **o<sub>i</sub>** and manual **o<sub>i</sub>** features that provide the same calibrated test as the automatic **o<sub>i</sub>**, and in addition actuate the Alarm

relay to verify output operation for preventive maintenance requirements. These features can be performed at any time and eliminate the need for testing with a non-calibrated external test lamp.

### **CAUTION**

*These tests require disabling of all extinguishing devices to avoid release resulting from a successful test.*

The magnetic **oi** test is performed by placing a magnet by the marked location (mag **oi**) on the outside of the detector. The manual **oi** test is accomplished by connecting the **oi** lead (terminal 22) to power supply minus via an external switch. The magnet or switch must be held in place for a minimum of 6 seconds to complete the test. Either of these test methods activates the calibrated UV emitter. If the resulting signal meets the test criteria, indicating that greater than half of the detection range remains, the Alarm relay changes state, the indicating LED changes to red, and the 4-20 mA current output goes to 20 mA. This condition remains until the magnet is removed or the switch is released. If the alarm relay is configured for non-latching operation, it will change states and the red LED will turn to green. If the unit has latching relays, the detector's operating software will automatically reset the relays with no operator action required.

If less than half of the detection range remains, no alarm is produced and a fault is generated. The fault indication can be reset by momentarily applying the magnet or manual **oi** switch.

### **NOTE**

*Refer to the Appendix for FM verification of Det-Tronics' patented Optical Integrity **oi**<sup>TM</sup> function.*

## **COMMUNICATION**

The X2200 is furnished with an RS-485 interface for communicating detector status and other information with external devices. The RS-485 uses MODBUS protocol, with devices configured as slaves.

### **NOTE**

*The EQP model uses LON/SLC communication. RS-485 communication is not available on the EQP model.*

## **DATA LOGGING / EVENT MONITORING**

Data logging for event monitoring capability is also provided. The detector can log up to 1500 events (up to 1000 general and 500 alarm events). Status

conditions such as normal, power down, general and **oi** faults, pre-alarm, fire alarm, time and temperature are recorded. Each event is time and date stamped, along with the temperature and input voltage. Event data is stored in non-volatile memory when the event becomes active, and again when the status changes. Data is accessible using the RS-485 port or the EQP controller.

## **INTEGRAL WIRING COMPARTMENT**

All external wiring to the device is connected within the integral junction box. The screw terminals accept wiring from 12 to 22 AWG. The detector is furnished with four conduit entries, with either 3/4 inch NPT or 25 mm threads.

## **SIGNAL PROCESSING OPTIONS**

The UV detector output (measured in counts per second) is compared to the fire threshold (the "sensitivity" setting). If the radiant energy level from the fire exceeds the selected alarm threshold level, the fire alarm output is activated. In every application, it is crucial to ensure that the radiant ultraviolet energy level from the expected fire at the required distance from the detector will exceed the selected sensitivity level.

The UV detector in the X2200 can be programmed for:

- Arc Rejection
- Standard Signal Processing.

### **Arc Rejection (Recommended Factory Setting)**

The Arc Rejection mode enables the detector to prevent nuisance fire alarms caused by UV from short-duration electrical arcs or electrostatic discharge, while maintaining the ability to reliably detect the UV given off by a flame. Typical applications that benefit from arc rejection logic include electrostatic coating processes and uncontrolled environments where transient UV sources can be present, such as many typical outdoor applications. Most false alarm sources have short transient UV signatures, while fire creates a long UV signature over many seconds. Most fires are detected in a few seconds (see response times in appendix).

### **Standard Signal Processing**

Standard signal processing is recommended for high-speed suppression systems only. To allow for high-speed operation, the standard processing mode does not incorporate the arc rejection programming. This mode should only be used in a controlled, indoor environment.

## **GENERAL APPLICATION INFORMATION**

### **RESPONSE CHARACTERISTICS**

Response is dependent on distance, type of fuel, temperature of the fuel, and time required for the fire to come to equilibrium. As with all fire tests, results must be interpreted according to an individual application.

See Appendix for fire test results.

### **WELDING**

Electric arc welding is a source of intense ultraviolet radiation. UV radiation from arc welding readily scatters and can deflect across significant distances, even when direct obstructions exist. Any open door or window can allow nuisance UV radiation from arc welding to enter an enclosed area.

It is recommended that the system be bypassed during welding operations in situations where the possibility of a false alarm cannot be tolerated. Gas welding mandates system bypass, since the gas torch is an actual fire.

### **ARTIFICIAL LIGHTING**

The X2200 should not be located within 3 feet of artificial lights. Excess heating of the detector could occur due to heat radiating from the lights.

### **EMI/RFI INTERFERENCE**

The X2200 is resistant to interference by EMI and RFI, and is EMC Directive compliant and CE Marked. It will not respond to a 5 watt walkie-talkie at distances greater than 1 foot.

### **FALSE ALARM SOURCES**

The UV sensor is solar blind to the ultraviolet component of solar radiation. However, it will respond to sources of UV besides fire, such as electric arc welding, lightning, high voltage corona, x-rays and gamma radiation.

## **FACTORS INHIBITING DETECTOR RESPONSE**

### **Windows**

Glass and Plexiglas windows significantly attenuate UV radiation and must not be located between the detector and a potential flame source. If the window cannot be eliminated or the detector location changed, contact Detector Electronics for recommendations regarding window materials that will not attenuate UV radiation.

### **Obstructions**

Radiation must be able to reach the detector in order for it to respond. Care must be taken to keep physical obstructions out of the line of view of the detector. In addition, UV absorbing gases or vapors must not be allowed to accumulate between the detector and the protected hazard. See Table 3 for a list of these substances.

### **Smoke**

Smoke will absorb UV radiation. If accumulations of dense smoke can be expected to precede the presence of a flame, then detectors that are used in enclosed areas should be mounted on the wall approximately 3 feet (1 meter) from the ceiling where the accumulation of smoke is reduced.

### **Detector Viewing Windows**

It is important to keep the detector viewing windows as free of contaminants as possible in order to maintain maximum sensitivity. Commonly encountered substances that can significantly attenuate UV radiation include, but are certainly not limited to, the following:

- Silicones
- Oils and greases
- Dust and dirt buildup
- Paint overspray.

Table 3

**UV Absorbing Gases and Vapors**

The following is a partial list of compounds that exhibit significant UV absorption characteristics. These are also usually hazardous vapors. While generally of little consequence in small amounts, these gases can restrict UV detection if they are in the atmosphere in heavy concentrations. It should also be determined whether or not large amounts of these gases may be released as a result of a fire-causing occurrence.

Acetaldehyde	Methyl Methacrylate
Acetone	Alpha-Methylstyrene
Acrylonitrile	Naphthalene
Ethyl Acrylate	Nitroethane
Methyl Acrylate	Nitrobenzene
Ethanol	Nitromethane
Ammonia	1-Nitropropane
Aniline	2-Nitropropane
Benzene	2-Pentanone
1,3 Butadiene	Phenol
2-Butanone	Phenyl Glycide Ether
Butylamine	Pyridine
Chlorobenzene	Hydrogen Sulfide
1-Chloro-1-Nitropropane	Styrene
Chloroprene	Tetrachloroethylene
Cumene	Toluene
Cyclopentadiene	Trichloroethylene
O-Dichlorobenzene	Vinyl Toluene
P-Dichlorobenzene	Xylene

If UV-absorbing gases may be a factor in a given application, precautionary measures should be taken. Detectors can be placed closer to the potential hazard area, and/or the sensitivity of the detection system can be increased. Contact the factory for further details.

Substances such as methane, propane, butane, hexane, camphor and octane are not UV absorbing.

**IMPORTANT SAFETY NOTES****WARNING**

*Do not open the detector assembly in a hazardous area when power is applied. The detector contains limited serviceable components and should never be opened. Doing so could disturb critical optical alignment and calibration parameters, possibly causing serious damage. This type of damage could be undetected and could result in failure to see a fire and/or false alarm.*

**CAUTION**

*The wiring procedures in this manual are intended to ensure proper functioning of the device under normal conditions. However, because of the many variations in wiring codes and regulations, total compliance to these ordinances cannot be guaranteed. Be certain that all wiring complies with the NEC as well as all local ordinances. If in doubt, consult the authority having jurisdiction before wiring the system. Installation must be done by a properly trained person.*

**CAUTION**

*To prevent unwanted actuation or alarm, extinguishing devices must be disabled prior to performing detection system tests or maintenance.*

**ATTENTION**

*Remove the protective cap from the front of the detector before activating the system.*

**ATTENTION**

*Observe precautions for handling electrostatic sensitive devices.*

## INSTALLATION

### NOTE

The recommended lubricant for threads and O-rings is a silicone free grease (part number 005003-001) available from Detector Electronics. Under no circumstances should a lubricant containing silicone be used.

## DETECTOR POSITIONING

Detectors should be positioned to provide the best unobstructed view of the area to be protected. The following factors should also be taken into consideration:

- Identify all high risk fire ignition sources.
- Be sure that enough detectors are used to adequately cover the hazardous area.
- Be sure that the unit is easily accessible for cleaning and other periodic servicing.
- Locate and position the detector so that the fire hazard(s) are within both the field of view and detection range of the device. Refer to Appendix for specific information.
- The detector should be aimed downward at least 10 to 20 degrees to allow lens openings to drain. See Figure 1. **The detector should be positioned so that its field of view does not cover areas outside the hazardous area.** This will minimize the possibility of false alarms caused by activities outside the area requiring protection.
- For best performance, the detector should be mounted on a rigid surface in a low vibration area.
- Dense fog, rain as well as certain gases and vapors (see Table 3) can absorb UV radiation and reduce the sensitivity of the detector.
- Verify that all detectors in the system are properly aimed at the area to be protected. (The Det-Tronics Q1201C Laser Aimer is recommended for this purpose.)
- If possible, fire tests should be conducted to verify correct detector positioning and coverage.

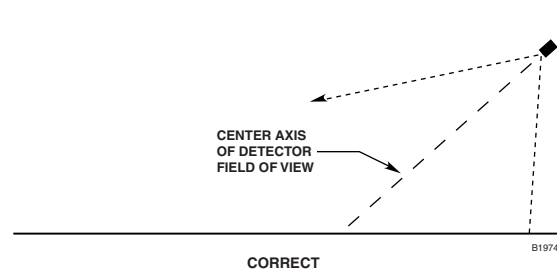
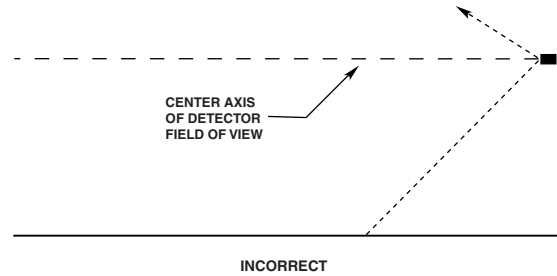

NOTE: DETECTOR MUST ALWAYS BE AIMED DOWNWARD AT LEAST 10 TO 20 DEGREES.

Figure 1—Detector Orientation Relative to Horizon

## DETECTOR ORIENTATION

Refer to Figure 2 and ensure that the **oi** plate will be oriented as shown when the X2200 is mounted and sighted. This will ensure proper operation of the **oi** system and will also minimize the accumulation of moisture and contaminants between the **oi** plate and the viewing windows.

### IMPORTANT

**The **oi** plate must be securely tightened to ensure proper operation of the **oi** system (40 oz./inches recommended).**



Figure 2—Front View of the X2200



## PROTECTION AGAINST MOISTURE DAMAGE

It is important to take proper precautions during installation to ensure that moisture will not come in contact with the electrical connections of the system. The integrity of the system regarding moisture protection must be maintained for proper operation and is the responsibility of the installer.

If conduit is used, drains must be installed at water collection points to automatically drain accumulated moisture. Conduit breathers should be installed at upper locations to provide ventilation and allow water vapor to escape. At least one breather should be used with each drain.

Conduit raceways should be inclined so that water will flow to low points for drainage and will not collect inside enclosures or on conduit seals. If this is not possible, install conduit drains above the seals to prevent the collection of water or install a drain loop below the detector with a conduit drain at the lowest point of the loop.

Conduit seals are not required for compliance with explosion-proof installation requirements, but are highly recommended to prevent water ingress in outdoor applications. Units with M25 thread must use an IP66 washer or an O-ring sealed adapter/gland to prevent water ingress.

## WIRING PROCEDURE

### Wire Size and Type

The system should be wired using a 12 to 22 gauge (2.5 to 0.3 mm<sup>2</sup>) cable. The wire size selected should be based on the number of detectors connected, the supply voltage and the cable length. Wires should be stripped 3/8 inch (9 mm). A minimum input voltage of 18 vdc must be present at the X2200.

#### NOTE

*Refer to "Power Consumption" in the "Specifications" section of this manual.*

The use of shielded cable is required to protect against interference caused by EMI and RFI. When using cables with shields, terminate the shields as shown in Figures 7 through 12, and Figure 14. Consult the factory if not using shielded cable.

In applications where the wiring cable is installed in conduit, the conduit must not be used for wiring to other electrical equipment.

#### CAUTION

*Installation of the detector and wiring should be performed only by qualified personnel.*

### Detector Mounting

Install the swivel mounting bracket assembly on the wall. The installation surface should be free of vibration and suitable to receive 1/4 inch (M6) screws with a length of at least 1 inch (25 mm), and have sufficient capacity to hold the detector and bracket weight. Refer to Figure 3 for dimensions.

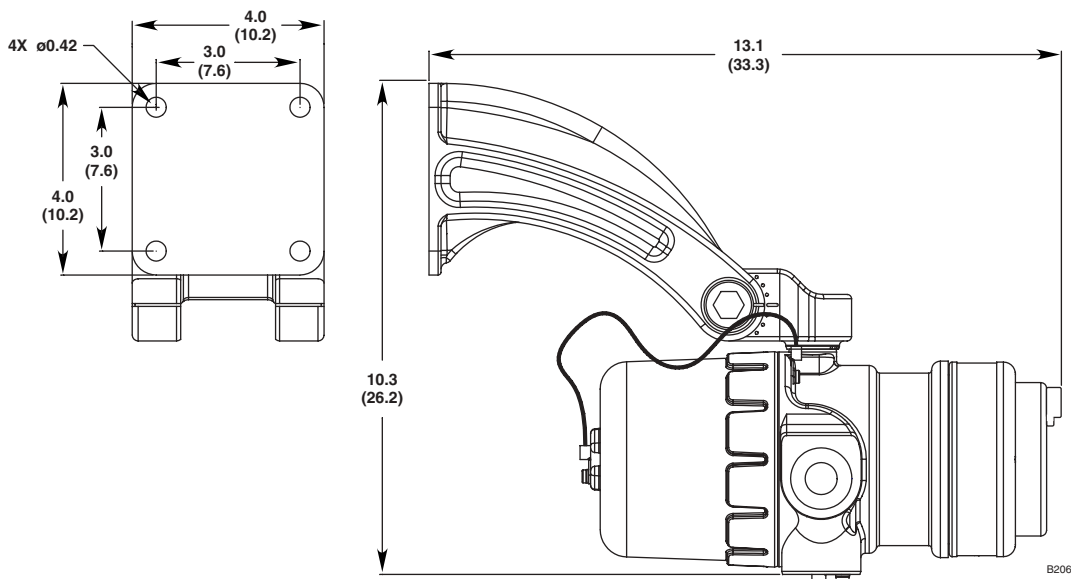

Figure 3—Q9033B Mounting Bracket Dimensions in Inches (cm)  
(Refer to Figure 1 for Correct Detector Orientation)

## Relay and 4-20 mA Output Models

Follow the instructions below to install the X2200.

1. Make field connections following local ordinances and guidelines in this manual. Refer to Figures 4 through 12.
2. Check all field wiring to be sure that the proper connections have been made.

### IMPORTANT

*Do not test any wiring connected to the detector with a meg-ohmmeter. Disconnect wiring at the detector before checking system wiring for continuity.*

3. Make the final sighting adjustments and ensure that the mounting bracket hardware is tight.



Figure 4—X2200 Terminal Block

9	4-20 mA +	19	4-20 mA –	SPARE	29
8	4-20 mA + REF	18	4-20 mA – REF	SPARE	28
7	COM FIRE	17	COM FIRE	COM AUX	27
6	N.O. FIRE	16	N.O. FIRE	N.O. AUX	26
5	N.C. FIRE	15	N.C. FIRE	N.C. AUX	25
4	COM FAULT	14	COM FAULT	RS-485 A	24
3	N.O. FAULT	13	N.O. FAULT	RS-485 B	23
2	24 VDC +	12	24 VDC +	MAN Oi	22
1	24 VDC –	11	24 VDC –	24 VDC –	21

B2061

Figure 5—Wiring Terminal Identification

## EOL RESISTORS (Not Used with EQP Model)

To ensure that the insulating material of the wiring terminal block will not be affected by the heat generated by EOL resistors, observe the following guidelines when installing the resistors.

1. Required EOL resistor power rating must be 5 watts minimum.

### NOTE

*EOL resistors must be ceramic, wirewound type, rated 5 watts minimum, with actual power dissipation not to exceed 2.5 watts.*

2. Resistor leads should be cut to a length of approximately 1 1/2 inches (40 mm).
3. Bend the leads and install the EOL resistor as shown in Figure 6.
4. Maintain a 3/8 inch (10 mm) minimum gap between the resistor body and the terminal block or any other neighboring parts.

### NOTE

*All cable entry devices and blanking elements shall be certified to “E-generation” or “ATEX” standards, in type of explosion protection increased safety “e” or flameproof enclosure “d” (as applicable), suitable for the conditions of use and correctly installed. They shall maintain the degree of ingress protection IP66 for the apparatus. Unused apertures shall be closed with suitable blanking elements.*

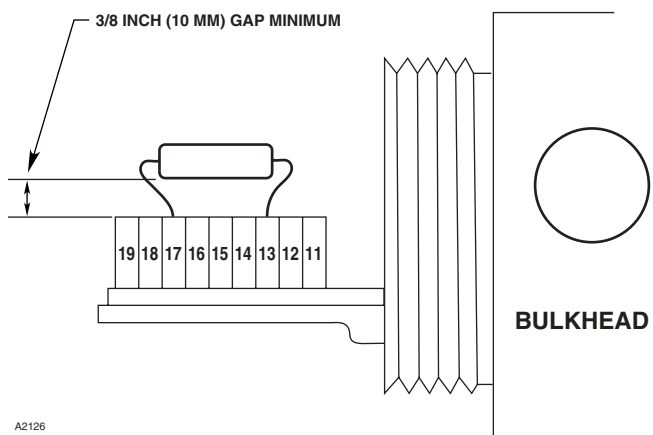

A2126

Figure 6—EOL Resistor Installation

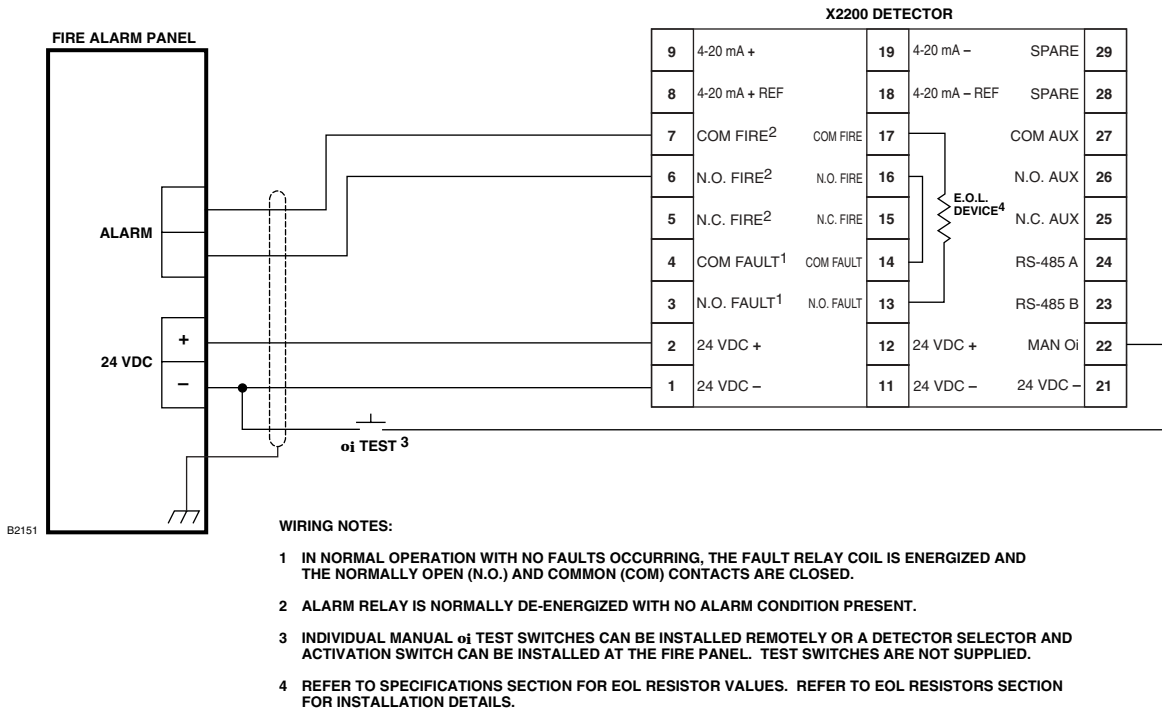

Figure 7—EEx d Wiring Option

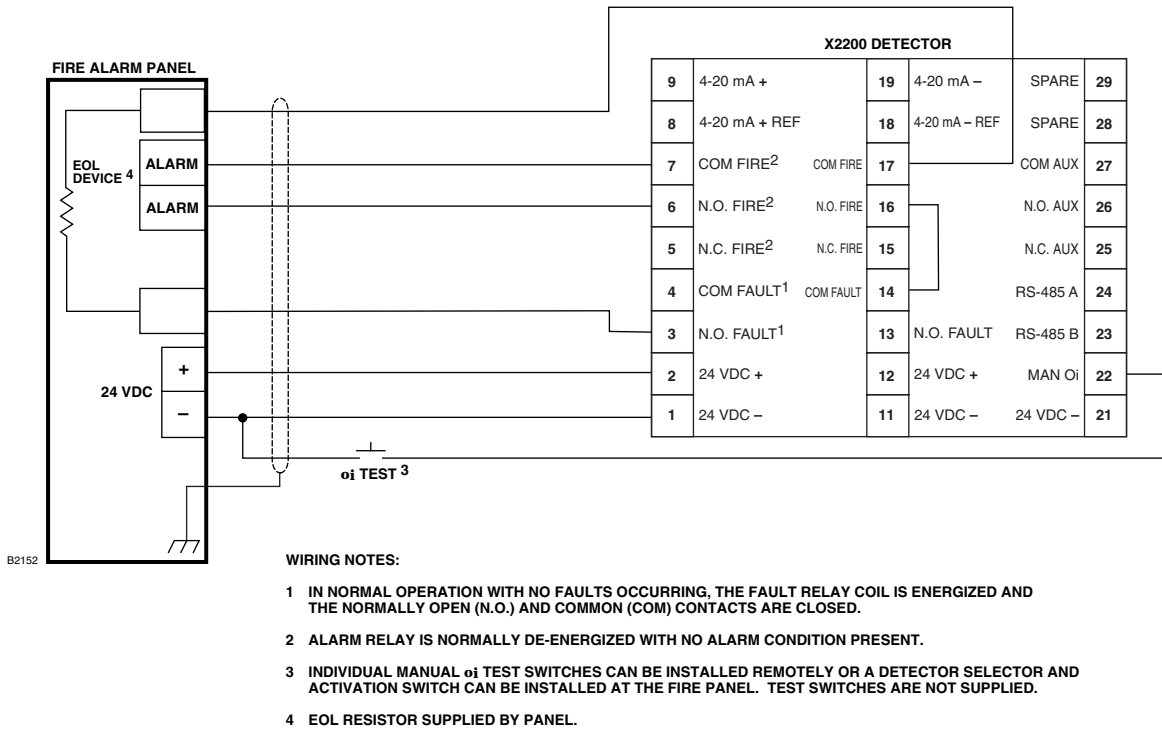

Figure 8—EEx e Wiring Option

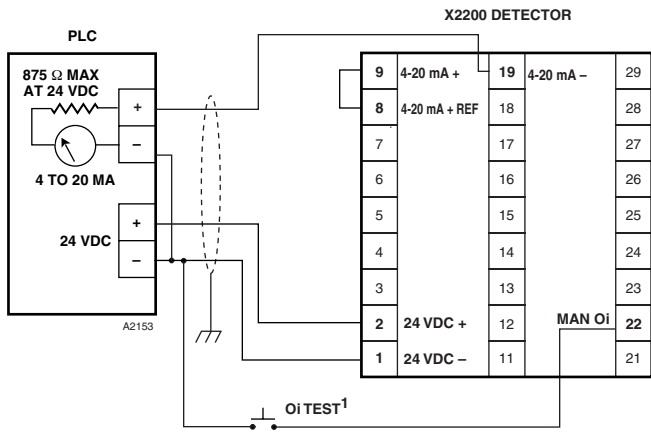

Figure 9—X2200 Detector Wired for Non-Isolated 4 to 20 ma Current Output (Sourcing)

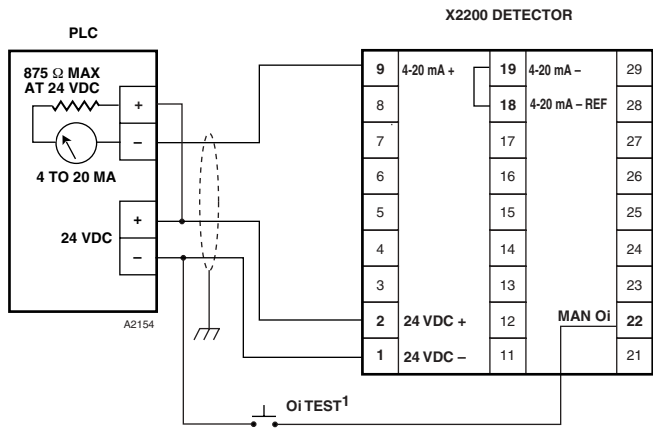

Figure 10—X2200 Detector Wired for Non-Isolated 4 to 20 ma Current Output (Sinking)

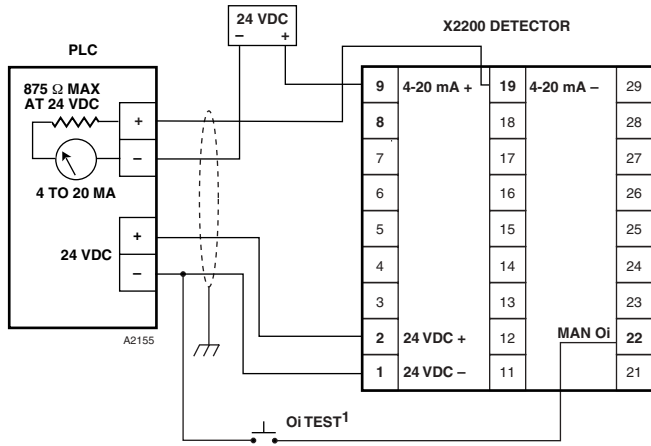

Figure 11—X2200 Detector Wired for Isolated 4 to 20 ma Current Output (Sourcing)

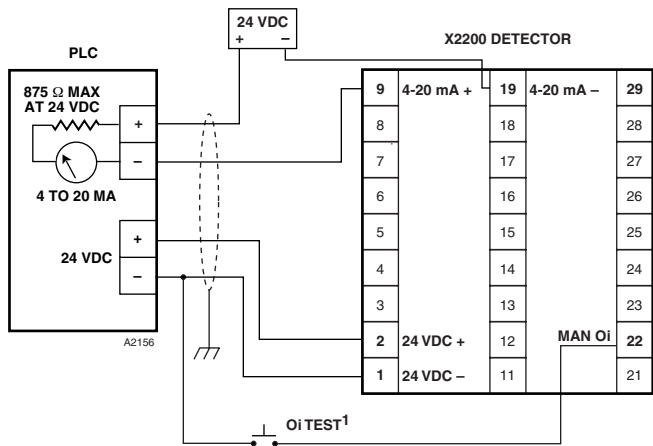

Figure 12—X2200 Detector Wired for Isolated 4 to 20 ma Current Output (Sinking)

**NOTES: 1. INDIVIDUAL MANUAL oi TEST SWITCHES CAN BE INSTALLED REMOTELY OR A DETECTOR SELECTOR AND ACTIVATION SWITCH CAN BE INSTALLED AT THE FIRE PANEL. TEST SWITCHES ARE NOT SUPPLIED.**

**EQP Model**

1. Connect external wires to the appropriate terminals inside the device junction box. (See Figure 13 for terminal identification.)
2. Connect the shield of the power cable to “earth ground” at the power source.
3. Connect shields for the LON cable as indicated. See Figure 14.

**NOTE**

*DO NOT ground any shields at the detector housing.*

4. Set the device network address. (See “Setting Device Network Addresses” section of this manual for switch setting procedure.)

5. Check all field wiring to be sure that the proper connections have been made.
6. Replace the device cover.
7. Make the final sighting adjustments and ensure that the mounting bracket hardware is tight.

**NOTE**

*Refer to the Eagle Quantum Premier system manual (number 95-8533) for information regarding power and network communication cable requirements.*

COM SHIELD	6	16	COM SHIELD
COM 1 A	5	15	COM 2 A
COM 1 B	4	14	COM 2 B
POWER SHIELD	3	13	POWER SHIELD
24 VDC +	2	12	24 VDC +
24 VDC -	1	11	24 VDC -

A2089

Figure 13—Wiring Terminal Identification for X2200 EQP Model

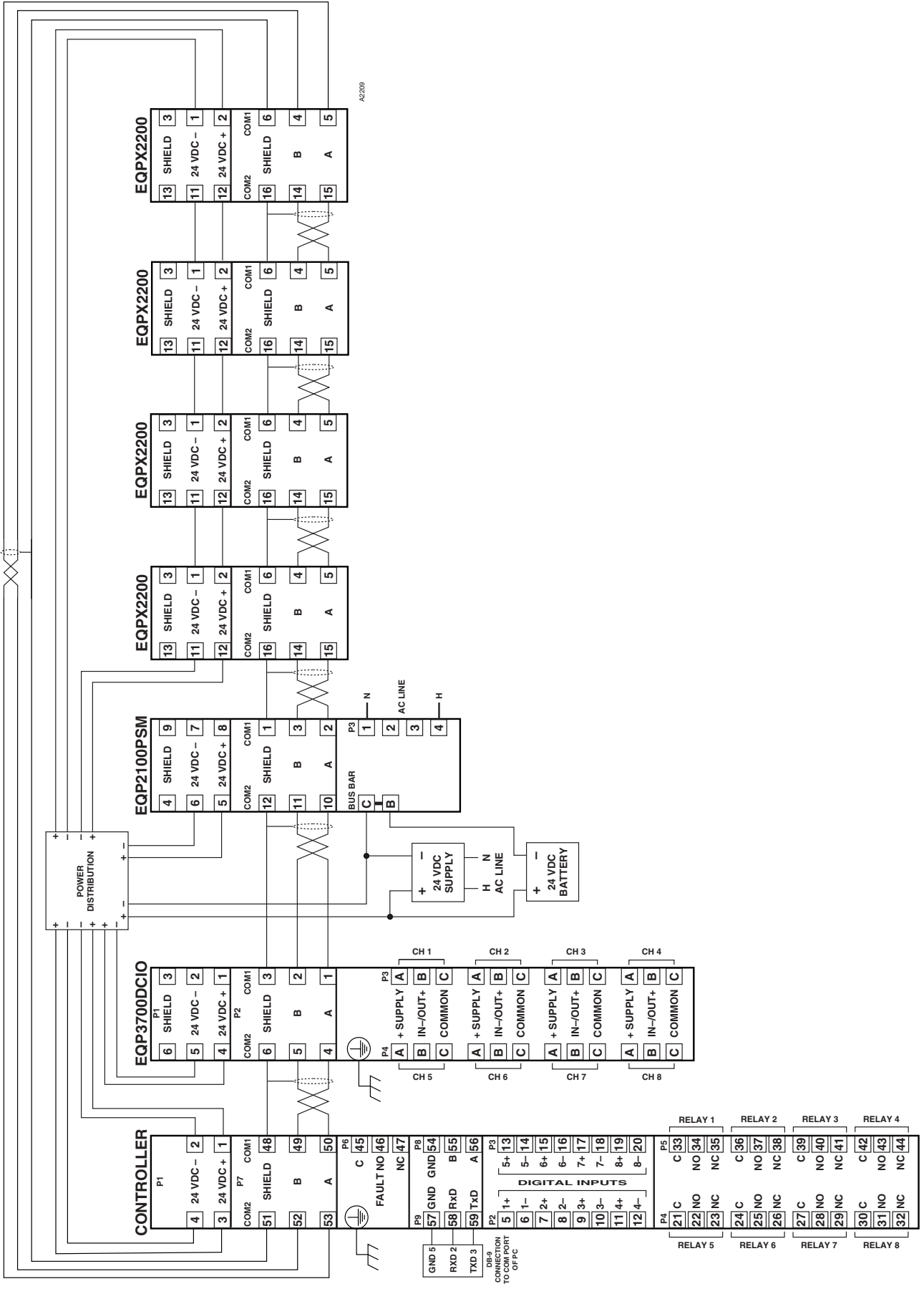

AC208

Figure 14—A Typical EQP System

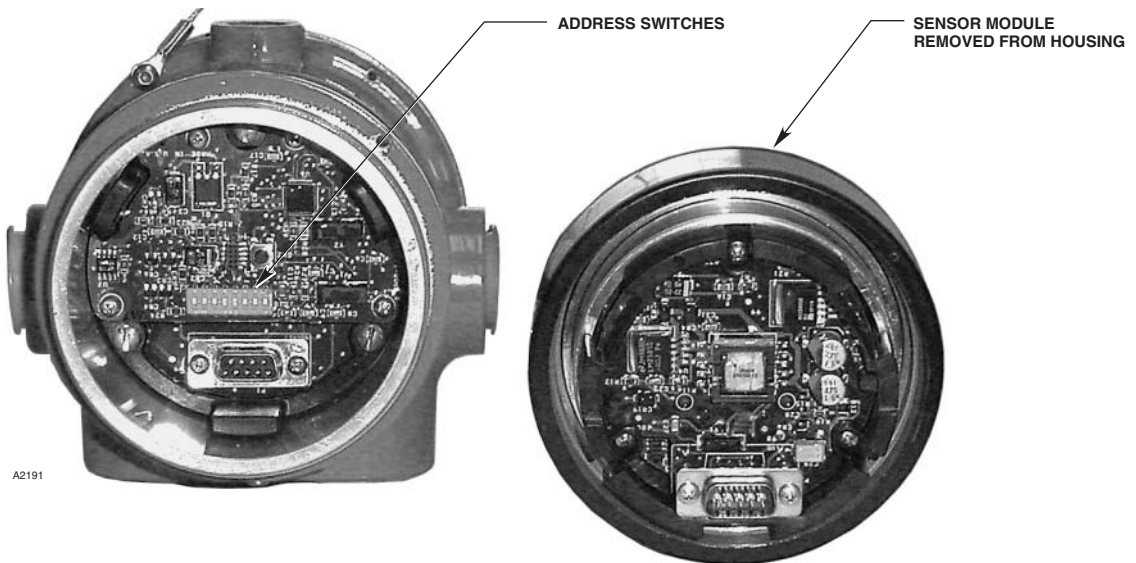

Figure 15—Location of Address Switches

## SETTING DEVICE NETWORK ADDRESSES (EQP Model Only)

### Overview of Network Addresses

Each device on the LON must be assigned a unique address. Addresses 1 to 4 are reserved for the controller. Valid addresses for field devices are from 5 to 250.

#### **IMPORTANT**

*If the address is set to zero or an address above 250, the switch setting will be ignored.*

Duplicated addresses are not automatically detected. Modules given the same address will use the number given and report to the controller using that address. The status word will show the latest update, which could be from any of the reporting modules using that address.

### Setting Field Device Addresses

Selection of the node address is done by setting rocker switches on an 8 switch “DIP Switch Assembly” within the detector’s housing. Refer to Figure 15 for switch location.

#### **WARNING**

*The network address switches are located within the detector housing. Disassembly of the detector head that contains powered electrical circuits is required to gain access to the network address switches. For hazardous areas, the area must be de-classified before attempting*

*disassembly of the device. Always observe precautions for handling electrostatic sensitive devices.*

The address number is binary encoded with each switch having a specific binary value with switch 1 being the LSB (Least Significant Bit). (See Figure 16) The device’s LON address is equal to the added value of all closed rocker switches. All “Open” switches are ignored.

**Example:** for node No. 5, close rocker switches 1 and 3 (binary values 1 + 4); for node No. 25, close rocker switches 1, 4 and 5 (binary values 1 + 8 + 16).

#### **NOTE**

*The field device sets the LON address only when power is applied to the device. Therefore, it is important to set the switches **before** applying power. If an address is ever changed, system power must be cycled before the new address will take effect.*

After setting address switches, record the address number and device type.

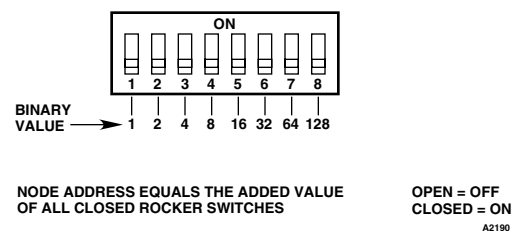

Figure 16—Address Switches for X2200

## STARTUP PROCEDURE

When installation of the equipment is complete, perform the “Fire Alarm Test” below.

### FIRE ALARM TEST

1. Disable any extinguishing equipment that is connected to the system.
2. Apply input power to the system.
3. Initiate an **oi** test. (See “Magnetic **oi** / Manual **oi**” under Optical Integrity in the Description section of this manual.)
4. Repeat this test for all detectors in the system. If a unit fails the test, refer to the “Troubleshooting” section.
5. Verify that all detectors in the system are properly aimed at the area to be protected. (The Det-Tronics Q1201C Laser Aimer is recommended for this purpose.)
6. Enable extinguishing equipment when the test is complete.

Table 4—Current Level Output Troubleshooting Guide

Current Level (±0.3 mA)	Status	Action
0 mA	General Fault	Check system wiring.
1 mA	Internal Power Supply Fault	Cycle power.
2 mA	Oi Fault	Clean windows.
4 mA	Normal Operation	
16 mA	Hi Background UV	Remove UV source or aim detector away from UV source.
20 mA	Fire Alarm	

## TROUBLESHOOTING

### WARNING

*The sensor module (“front” half of the detector) contains no user serviceable components and should never be opened. The terminal compartment is the only part of the enclosure that should be opened by the user in the field.*

1. Disable any extinguishing equipment that is connected to the unit.
2. Inspect the viewing windows for contamination and clean as necessary. (Refer to the “Maintenance” section for complete information regarding cleaning of the detector viewing windows.)
3. Check input power to the unit.
4. If the fire system has a logging function, check the fire panel log for output status information. See Table 4 for information regarding 4 to 20 mA output.
5. Turn off the input power to the detector and check all wiring for continuity. **Important: Disconnect wiring at the detector before checking system wiring for continuity.**
6. If all wiring checks out and cleaning of the **oi** plate/window did not correct the fault condition, check for high levels of background UV radiation by covering the detector with the factory supplied cover or aluminum foil. If the fault condition clears, extreme background UV radiation is present. Re-adjust the view of the detector away from the UV source or relocate the detector.

If none of these actions corrects the problem, return the detector to the factory for repair.

### NOTE

*It is highly recommended that a complete spare be kept on hand for field replacement to ensure continuous protection.*



## MAINTENANCE

### IMPORTANT

*Periodic flamepath inspections are not recommended, since the product is not intended to be serviced and provides proper ingress protection to eliminate potential deterioration of the flamepaths.*

### WARNING

*The sensor module (“front” half of the detector) contains no user serviceable components and should never be opened. The terminal compartment is the only part of the enclosure that should be opened by the user in the field.*

To maintain maximum sensitivity and false alarm resistance, the viewing windows of the X2200 must be kept relatively clean. Refer to the procedure below for cleaning instructions.

## CLEANING PROCEDURE

### CAUTION

*Disable any extinguishing equipment that is connected to the unit to prevent unwanted actuation.*

To clean the windows and **oi** plate, use Det-Tronics window cleaner (part number 001680-001) and a soft cloth, cotton swab or tissue and refer to the following procedure.

1. **Disable any extinguishing equipment that is connected to the unit.**

### NOTE

*Remove input power when cleaning the detector windows. The rubbing motion on the surface of the windows during cleaning can create static electricity that could result in unwanted output activation.*

2. To clean the optical surfaces, remove the **oi** plate following the procedure described below.
3. Thoroughly clean the viewing window and reflective surfaces of the **oi** plate using a clean cloth, cotton swab or tissue, and Det-Tronics window cleaning solution. If a stronger solution is needed, isopropyl alcohol may be used.
4. Re-install the **oi** plate following the procedure described below.

## oi PLATE REMOVAL

1. Loosen the two captive screws, then grasp the **oi** plate by the visor and remove it from the detector. See Figure 17.
2. Thoroughly clean the **oi** plate reflective surfaces, holding it by its edges to avoid leaving fingerprints on the inside reflective surface.
3. Re-install the **oi** plate. Ensure that the plate is flat on the detector surface. Tighten the **oi** plate screws securely (40 oz/inches).

### NOTE

*If the **oi** plate is removed, be sure to install the original **oi** plate. **oi** plates are not interchangeable and should not be mixed with **oi** plates from other detectors. If corrosive contaminants in the atmosphere cause the **oi** plate surface to deteriorate to the extent that it is no longer possible to restore it to its original condition, it must be replaced. Consult factory for **oi** plate replacement procedure.*

## PERIODIC CHECKOUT PROCEDURE

A checkout of the system using the manual or magnetic **oi** feature should be performed on a regularly scheduled basis to ensure that the system is operating properly.

## CLOCK BATTERY (Not used with EQP Model)

The real time clock has a backup battery that will operate the clock with no external power for nominally 10 years. It is recommended that the battery be replaced every 7 years. Return the device to the factory for battery replacement.

### NOTE

*If the backup battery is depleted, there is no effect on the operation of the flame detector, but the time stamping of the data log may be affected.*



Figure 17—Oi Plate Removal

## FEATURES

- Responds to a fire in the presence of modulated blackbody radiation (i.e. heaters, ovens, turbines) without false alarm.
- High speed capability.
- Built-in data logging / event monitoring, up to 1500 events (up to 1000 general, 500 alarms).
- Automatic, manual or magnetic optical integrity (**oi**) testing.
- Easily replaceable **oi** plate.
- Fire, fault and auxiliary relays standard.
- 4 to 20 mA isolated output (optional).
- Eagle Quantum Premier LON/SLC output (optional).
- Tricolor LED indicates normal operation, fire and fault conditions.
- Operates under adverse weather conditions.
- Mounting swivel allows easy sighting.
- Integral wiring compartment for ease of installation.
- Explosion-proof/flame-proof detector housing. Meets FM, CSA, CENELEC (ATEX Directive Compliant) and CE certification requirements.
- Class A wiring per NFPA-72.
- Meets NFPA-33 response requirement for under 0.5 second (available when model selected).
- 3 year warranty.
- Advanced signal processing (ARC).
- RFI and EMC Directive Compliant.

## SPECIFICATIONS

### OPERATING VOLTAGE—

24 volts dc nominal (18 vdc minimum, 30 vdc maximum). Maximum ripple is 2 volts peak-to-peak.

### POWER CONSUMPTION—

2.5 watts at 24 vdc nominal;  
4.5 watts at 24 vdc in alarm.  
2.8 watts at 30 vdc nominal;  
5.1 watts at 30 vdc in alarm.

Total power: 7.6 watts at 30 vdc with EOL resistor installed. EOL resistor must be ceramic, wirewound type, rated 5 watts minimum, with actual power dissipation not to exceed 2.5 watts.

### POWER UP TIME—

Fault indication clears after 0.5 second; device is ready to indicate an alarm condition after 30 seconds.

### OUTPUT RELAYS—

Fire Alarm relay, Form C, 5 amperes at 30 vdc:

The Fire Alarm relay has redundant terminals and normally open / normally closed contacts, normally de-energized operation, and latching or non-latching operation.

Fault relay, Form A, 5 amperes at 30 vdc:

The Fault relay has redundant terminals and normally open contacts, normally energized operation, and latching or non-latching operation.

Auxiliary relay, Form C, 5 amperes at 30 vdc:

The auxiliary relay has normally open / normally closed contacts, normally energized or de-energized operation, and latching or non-latching operation.

### CURRENT OUTPUT (Optional)—

4 to 20 milliampere dc current, with a maximum loop resistance of 500 ohms from 18 to 19.9 volts dc and 600 ohms from 20 to 30 volts dc.

### LON OUTPUT—

Digital communication, transformer isolated (78.5 kbps).

**TEMPERATURE RANGE—**

Operating: -40°F to +167°F (-40°C to +75°C).  
Storage: -67°F to +185°F (-55°C to +85°C).  
Hazardous location ratings from -55°C to +75°C available on flameproof model.

**HUMIDITY RANGE—**

0 to 95% relative humidity, can withstand 100% condensing humidity for short periods of time.

**CONE OF VISION—**

The detector has a 90° cone of vision (horizontal) with the highest sensitivity lying along the central axis. See Figure 18.

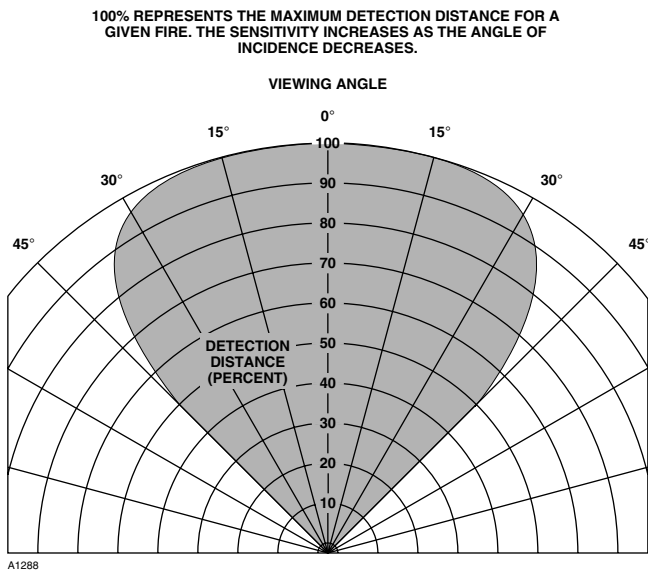

Figure 18—Detector Cone of Vision

**RESPONSE TIME—**

Less than 6 seconds. (See Appendix for details.)

**ENCLOSURE MATERIAL—**

Copper-free aluminum (red-painted) or 316 stainless steel.

**VIBRATION—**

Conformance per FM 3260: 2000, MIL-STD 810C (Curve AW), DNV Note 2.4 (Class B).

**DIMENSIONS—**

See Figure 19.

**WIRING—**

12 AWG (2.5 mm<sup>2</sup>) to 22 AWG (0.3 mm<sup>2</sup>) shielded cable is recommended.

**Important:** 18 vdc minimum must be available at the detector. For ambient temperatures below -10°C and above +60°C use field wiring suitable for both minimum and maximum ambient temperature.

**THREAD SIZE—**

Conduit connection: Four entries, 3/4 inch NPT or M25. Conduit seal not required.

**SHIPPING WEIGHT (Approximate)—**

Aluminum: 6 pounds (2.7 kilograms).  
Stainless Steel: 10 pounds (4.5 kilograms).  
Swivel Mount: 14 pounds (6.4 kilograms).

**WARRANTY PERIOD—**

**3 years.**

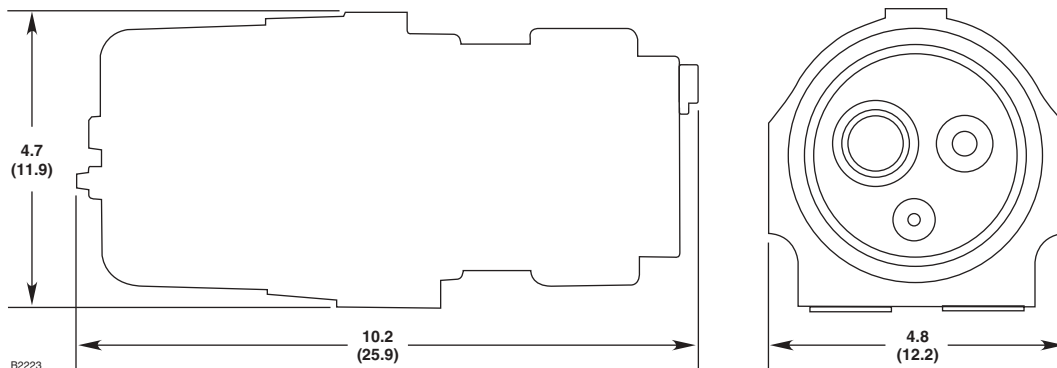

Figure 19—Dimensions in Inches (cm)

## CERTIFICATION—



Class I, Div. 1, Groups B, C and D;  
Class II, Div. 1, Groups E, F, and G;  
Class I, Div. 2, Groups A, B, C and D (T3);  
Class II, Div. 2, Groups F and G (T3);  
Class III.  
Enclosure NEMA/Type 4X.

### Increased Safety Model

CE 0539 Ex II 2 GD

EEx de IIC T5–T6 T86°C

DEMKO 02 ATEX 132195

T6 ( $T_{amb} = -55^{\circ}\text{C}$  to  $+60^{\circ}\text{C}$ ).

T5 ( $T_{amb} = -55^{\circ}\text{C}$  to  $+75^{\circ}\text{C}$ ).

IP66.

### Flameproof Model

CE 0539 Ex II 2 GD

EEx d IIC T5–T6 T86°C

DEMKO 02 ATEX 132195

T6 ( $T_{amb} = -55^{\circ}\text{C}$  to  $+60^{\circ}\text{C}$ ).

T5 ( $T_{amb} = -55^{\circ}\text{C}$  to  $+75^{\circ}\text{C}$ ).

IP66.

Conforms with: Low Voltage Directive (73/23/EEC).  
Electromagnetic Compatibility Directive  
(89/336/EEC).  
Explosive Atmosphere Directive  
(94/9/EC).  
Construction Product Directive.

VdS Performance verified per EN54-10,  
Certificate G-203083.

### NOTE

*Operational performance verified from  $-40^{\circ}\text{C}$  to  $+75^{\circ}\text{C}$ .*

### NOTE

*Refer to “EOL Resistors” section for installation details. All cable entry devices and blanking elements shall be certified to “E-generation” or “ATEX” standards, in type of explosion protection increased safety “e” or flameproof enclosure “d” (as applicable), suitable for the conditions of use and correctly installed. They shall maintain the degree of ingress protection IP66 for the apparatus. Unused apertures shall be closed with suitable blanking elements.*

## REPLACEMENT PARTS

The detector is not designed to be repaired in the field. If a problem should develop, refer to the Troubleshooting section. If it is determined that the problem is caused by an electronic defect, the device must be returned to the factory for repair.

## DEVICE REPAIR AND RETURN

Prior to returning devices, contact the nearest local Detector Electronics office so that a Service Order number can be assigned. A written statement describing the malfunction must accompany the returned device or component to expedite finding the cause of the failure.

Pack the unit properly. Use sufficient packing material in addition to an antistatic bag as protection from electrostatic discharge.

Return all equipment transportation prepaid to the factory in Minneapolis.

### NOTE

*It is highly recommended that a complete spare be kept on hand for field replacement to ensure continuous protection.*

## ORDERING INFORMATION

When ordering, please specify:

X2200 UV Flame Detector

Refer to the X2200 OS Matrix below for details.

### ACCESSORIES

**Q9033B Swivel Mount Assembly** is required for mounting the detector.

**Q1116A Air Shield** for use in dirty environments.

**Q1201C Laser Aimer** is recommended for verifying detector aiming.

**Weather Shield** is available for outdoor environments.

For assistance in ordering a system to fit your application, please contact:

Detector Electronics Corporation  
 6901 West 110th Street  
 Minneapolis, Minnesota 55438 USA  
 Operator: (952) 941-5665 or (800) 765-FIRE  
 Customer Service: (952) 946-6491  
 Fax: (952) 829-8750  
 E-mail: [detronics@detronics.com](mailto:detronics@detronics.com)

or contact your local sales office, which can be found on the Det-Tronics web site:

**[www.detronics.com](http://www.detronics.com)**

### REPLACEMENT PARTS

#### Part Number Description

001680-001 Window cleaner squeeze bottle  
 (package of six bottles)  
 005003-001 Silicone-free grease

### X2200 OS Matrix

MODEL	DESCRIPTION	
X2200	UV Flame Detector	
X2200M	UV Flame Detector with Molybdenum Tube	
	TYPE	MATERIAL
	A	Aluminum
	S	Stainless Steel (316)
	TYPE	THREAD TYPE
	4M	4 PORT, METRIC M25
	4N	4 PORT, 3/4" NPT
	TYPE	OUTPUTS
	11	Relay
	13	Relay and 4-20 mA
	14	Eagle Quantum Premier
	15	Relay and Pulse
	16	Addressable Module Only (Third Party Type)
	24	Eagle Quantum
	TYPE	APPROVAL AGENCY
	W	FM/CSA/CENELEC/CE
	TYPE	CLASSIFICATION**
	1	Division/Zone EEx de
	2	Division/Zone EEx d

\*\*Detectors are always Class I, Div. 1.

# APPENDIX

## FM Approvals Description and Performance Report

THE FOLLOWING ITEMS, FUNCTIONS AND OPTIONS DESCRIBE THE FM APPROVAL:

- Explosion-proof for Class I, Div. 1, Groups B, C and D Hazardous (Classified) Locations per FM 3615.
- Dust-ignition proof for Class II/III, Div. 1, Groups E, F and G Hazardous (Classified) Locations per FM 3615.
- Explosion-proof for Class I, Div. 2, Groups A, B, C and D (T3) Hazardous (Classified) Locations per FM 3611.
- Explosion-proof for Class II, Div. 2, Groups F and G (T3) Hazardous (Classified) Locations per FM 3611.
- Enclosure rating NEMA Type 4X per NEMA 250.
- Ambient Temperature Limits: -40°F to +167°F (-40°C to +75°C).
- Automatic Fire Alarm Signaling Performance verified per FM 3260 (2000).

The following performance criteria were verified:

### OPTICAL INTEGRITY TEST:

The detector generated an optical fault in the presence of contamination on any single or combination of lens surfaces resulting in a loss of approximately half of its detection range, verifying that the detector performs a calibrated Automatic Optical Integrity (**oi**) test for the sensor. Upon removal of the contamination, the detector fault was cleared and the detector was verified to detect a fire.

The Manual / Magnetic **oi** performs the same calibrated test as the Automatic **oi**, and additionally actuates the alarm relay to verify output operation. If there is a loss of half of its detection range, an alarm signal is not generated.

### RESPONSE CHARACTERISTICS:

#### Very High Sensitivity

Fuel	Size	Distance (feet)	Typical Response Time (seconds)*	Mode
n-Heptane	1 x 1 foot	85	3	Low Arc
Methane	32 inch plume	100	2	Low Arc

#### High Sensitivity

Fuel	Size	Distance (feet)	Typical Response Time (seconds)*	Mode
n-Heptane	1 x 1 foot	60	1	Standard
n-Heptane	1 x 1 foot	60	1	Hi Arc
n-Heptane	1 x 1 foot	60	6	Very Hi Arc
Methane	32 inch plume	70	1	Standard
Methane	32 inch plume	70	1	Hi Arc
Methane	32 inch plume	70	1	Very Hi Arc

#### Medium Sensitivity

Fuel	Size	Distance (feet)	Typical Response Time (seconds)*	Mode
n-Heptane	1 x 1 foot	50	2	Standard
n-Heptane	1 x 1 foot	50	2	Hi Arc
Methane	32 inch plume	55	2	Standard
Methane	32 inch plume	55	2	Hi Arc

\*Add 2 seconds for EQP Model.

**FM Approvals Description and Performance Report – Continued**

**RESPONSE CHARACTERISTICS IN THE PRESENCE OF FALSE ALARM SOURCES:**

**Very High Sensitivity (Standard Mode)**

False Alarm Source	Distance feet (m)	Fire Source	Distance (feet)	Typical Response Time (seconds)*
Sunlight, direct, modulated, reflected	-	6-inch propane	10	<30
6 kw heater, modulated & unmodulated	10 (3)	1 x 1 foot n-Heptane	75	1
250 w vapor lamp, modulated & unmodulated	3 (0.9)	1 x 1 foot n-Heptane	75	1
300 w incandescent lamp, modulated & unmodulated	3 (0.9)	1 x 1 foot n-Heptane	75	1
1500 w electric radiant heater, modulated & unmodulated	10 (3)	1 x 1 foot n-Heptane	75	1
2-34 w fluorescent lamps, modulated & unmodulated	3 (0.9)	1 x 1 foot n-Heptane	75	1

**FALSE ALARM IMMUNITY:**

**Very High Sensitivity (Standard Mode)**

False Alarm Source	Distance feet (m)	Modulated Response	Unmodulated Response
Sunlight, direct, reflected	-	No Alarm	No Alarm
Vibration	N/A	No Alarm	No Alarm
6 kw heater	3 (0.9)	No Alarm	No Alarm
250 w vapor lamp	3 (0.9)	No Alarm	No Alarm
300 w incandescent lamp	3 (0.9)	No Alarm	No Alarm
1500 w electric radiant heater	3 (0.9)	No Alarm	No Alarm
2-34 w fluorescent lamps	3 (0.9)	No Alarm	No Alarm

\*Add 2 seconds for EQP Model.

**FM Approvals Description and Performance Report – Continued**

**FIELD OF VIEW:**

**Very High Sensitivity**

Fuel	Size	Distance (feet)	Horizontal (degrees)	Typical Response (seconds)*	Vertical (degrees)	Typical Response (seconds)*	Mode
n-Heptane	1 x 1 foot	42.5	+45	1	+45	1	Low Arc
			-45	1	-30	1	
Methane	32 inch plume	50	+45	2	+45	1	Low Arc
			-45	1	-30	1	

**High Sensitivity**

Fuel	Size	Distance (feet)	Horizontal (degrees)	Typical Response (seconds)*	Vertical (degrees)	Typical Response (seconds)*	Mode
n-Heptane	1 x 1 foot	30	+45	1	+45	1	Standard
			-45	1	-30	1	
n-Heptane	1 x 1 foot	30	+45	1	+45	1	Hi Arc
			-45	1	-30	1	
n-Heptane	1 x 1 foot	30	+45	2	+45	1	Very Hi Arc
			-45	1	-30	1	
Methane	32 inch plume	40	+45	1	+45	1	Standard
			-45	1	-30	1	
Methane	32 inch plume	40	+45	1	+45	1	Hi Arc
			-45	1	-30	1	
Methane	32 inch plume	35	+45	1	+45	1	Very Hi Arc
			-45	1	-30	1	

**Medium Sensitivity**

Fuel	Size	Distance (feet)	Horizontal (degrees)	Typical Response (seconds)*	Vertical (degrees)	Typical Response (seconds)*	Mode
n-Heptane	1 x 1 foot	25	+45	1	+45	1	Standard
			-45	1	-30	1	
n-Heptane	1 x 1 foot	25	+45	1	+45	1	Hi Arc
			-45	1	-30	1	
Methane	32 inch plume	30	+45	1	+45	1	Standard
			-45	1	-30	1	
Methane	32 inch plume	30	+45	1	+45	1	Hi Arc
			-45	1	-30	1	

\*Add 2 seconds for EQP Model.



## FM Approvals Description and Performance Report – Continued

### MODEL X2200M

The X2200M uses a sensor that has a broader spectrum than the standard sensor. It is designed to detect fires with unusual chemistry such as black powder. Consult factory for usage recommendations.

#### X2200M RESPONSE CHARACTERISTICS:

##### High Sensitivity

Fuel	Size	Distance (feet)	Typical Response Time (seconds)	Mode
Black Powder	40 grams	10	0.1	Standard

#### X2200M RESPONSE CHARACTERISTICS IN THE PRESENCE OF FALSE ALARMS

##### High Sensitivity (Standard Mode)

False Alarm Source	Distance feet (m)	Fire Source	Distance (feet) m	Typical Response Time (seconds)*
Sunlight, direct, reflected, modulated & unmodulated		2-inch dia n-Heptane	10 (3)	<15
70 w sodium vapor lamp, modulated & unmodulated	3 (0.9)	1 x 1 foot n-Heptane	40 (12)	0.1
250 w vapor lamp, modulated & unmodulated	3 (0.9)	1 x 1 foot n-Heptane	40 (12)	0.1
300 w incandescent lamp, modulated & unmodulated	3 (0.9)	1 x 1 foot n-Heptane	40 (12)	0.1
500 w halogen lamp, modulated & unmodulated	3 (0.9)	1 x 1 foot n-Heptane	40 (12)	0.1
1500 w electric radiant heater, modulated & unmodulated	10 (3)	1 x 1 foot n-Heptane	40 (12)	0.1
2-34 w fluorescent lamps, modulated & unmodulated	3 (0.9)	1 x 1 foot n-Heptane	40 (12)	0.1

#### X2200M FALSE ALARM IMMUNITY:

##### High Sensitivity (Standard Mode)

False Alarm Source	Distance feet (m)	Modulated Response	Unmodulated Response
Sunlight, direct, reflected		No Alarm	No Alarm
70 w sodium vapor lamp	3 (0.9)	No Alarm	No Alarm
250 w vapor lamp	3 (0.9)	No Alarm	No Alarm
300 w incandescent lamp	3 (0.9)	No Alarm	No Alarm
500 w halogen lamp	3 (0.9)	No Alarm	No Alarm
1500 w electric radiant heater	3 (0.9)	No Alarm	No Alarm
2-34 w fluorescent lamps	3 (0.9)	No Alarm	No Alarm

## FM Approvals Description and Performance Report – Continued

### X2200M FIELD OF VIEW:

#### High Sensitivity (Standard Mode)

Fuel	Size	Distance (feet)	Horizontal (degrees)	Typical Response (seconds)	Vertical (degrees)	Typical Response (seconds)
Black Powder	40 grams	5	+45	0.1	+45	0.1
			-45	0.1	-30	0.1



Printed in USA

Detector Electronics Corporation  
6901 West 110th Street • Minneapolis, Minnesota 55438 USA  
Tel: 952.941.5665 or 800.765.3473 • Fax: 952.829.8750