

SPC-ET PHOTOELECTRIC BEAM DETECTOR MOUNTING GUIDELINES

When installing the SPC-ET Beam Detectors, it is important that the following guidelines are adhered to:

- ❑ Do not mount in locations that are exposed to extremely high temperatures or water vapour.
- ❑ Do not mount SPC-ET within 300mm of any obstruction.
- ❑ Do not mount where the distance between the Emitter and Receiver is less than 5 metres or greater than 100 metres.
- ❑ Make sure the surface that the SPC-ET units are to be mounted on is rigid (ideally part of the building structure) to avoid any possibility of movement.
- ❑ When fixing the SPC-ET allow enough space to gain access to the sight hole for aligning purposes (this is located on the top right hand side of the Receiver unit, when viewed from the front).

List of Parts

The SPC-ET Beam Detector kit consists of three separate parts: -

- ❑ SPC-ET Receiver and Emitter.
- ❑ SPC-ET Receiver and Emitter interface kit (including 2 way and 10 way ribbon cables).
- ❑ Test Filters (25%, 50% and 60%).

Mounting the SPC-ET Beam Detector (c/w SPC-ET 2WI Interface Kit)

The SPC-ET Beam Detectors are designed to mount vertically onto Dual Gang back boxes (suggested type is Appleby AL5136). These boxes should be fixed securely to the wall and directly opposite each other, they must also be mounted the same distance from the ceiling at each end.

Wiring and Set Up

There are three main wiring methods available for the SPC-ET Beam Detector depending on the application. These are shown below. These and other wiring methods are explained in our Application Note AP097 available from our website. In all methods, cables should be brought through the top of the back box, and terminated into the appropriate connector blocks.

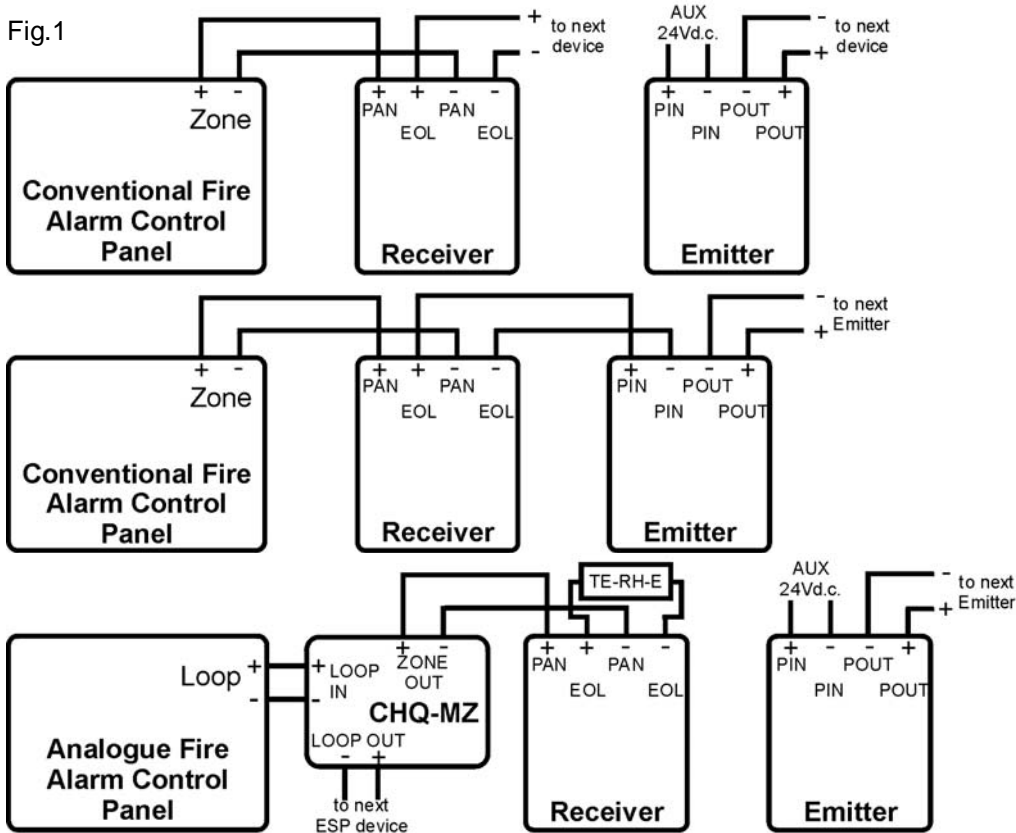

Method One

The Receiver is wired directly to the zone from the conventional panel. The Emitter is powered by a separate power supply.

Method Two

The Receiver is wired directly to the zone from the conventional panel and the Emitter is also powered via the conventional zone.

Method Three

The Receiver is wired directly to the loop from the analogue panel via a CHQ-MZ Mini Zone Monitor*. The Emitter is powered by a separate power supply, but can also be powered directly from the ESP loop if required.

*The CHQ-Z Dual Zone Monitor can also be used to interface the SPC-ET to the analogue loop, but this device requires an additional auxiliary 24Vd.c. power supply.

There is a set of jumpers on the rear of the Receiver interface kit PCB, these relate to three types of zone fault monitoring that can be selected. These are, schottky diode, zener diode and open circuit, the link settings can be found listed below:

Schottky Diode - LK1, LK3, LK4 and LK6 are all made

Zener Diode - LK2 and LK5 are made

No line continuity (open circuit) - LK1, LK4 and LK6 are all made (this setting is recommended when used with either the CHQ-MZ, CHQ-Z, CHQ-SZM or CHQ-DZM modules)

The Receiver interface kit can now be screwed to the Dual Gang back box.

The same procedure should be carried out at the Emitter end by terminating the power cables, the power for the Emitter can be obtained directly from the conventional zone, an Aux. 24Vd.c supply or directly from an ESP Loop (see Fig.1). The cables should be passed through the top of the back box and then connected into the four way connector block. The four-way connector block should then be pushed onto the four-pin socket located on the rear of the Interface Kit PCB. The Emitter interface kit should then be screwed to the Dual Gang back box.

The Emitter unit can now be fixed to the Interface kit by terminating the two-way ribbon cable (brown & red) into the push friction connectors on the front of the unit (these are not polarity conscious). This is achieved by opening the Emitter cover by pressing the sides of the cover at the top and then lifting and pulling gently (please refer to Fig.2.). The stripped ends of the cable should then be passed through the back of the Emitter, and located into the push friction connectors (E1 and E2) on the front of the unit by gently pushing the white slotted sections of the connector with a small screwdriver. The cables can then be pushed into the holes and the white slotted sections of the connector can be released, this should then grip the cable securely.

The two-part black connector can then be pushed onto the two pins on the front of the PCB.

The Emitter can then be mounted onto the Interface kit by aligning the four mounting slots on the rear of the Emitter with the four mounting hooks on the mounting bracket and then sliding the Emitter down gently.

The 10-way ribbon cable can now be fixed to the Receiver. This is achieved by opening the Receiver cover (refer to Fig.2) and passing the cable through the back of the unit. Starting with the black cable in NC, terminate each cable (from right to left) in order finishing with the white cable in the FC connector (Please refer to Fig.3.).

The 10-way black connector can then be pushed onto the connector on the front of the PCB.

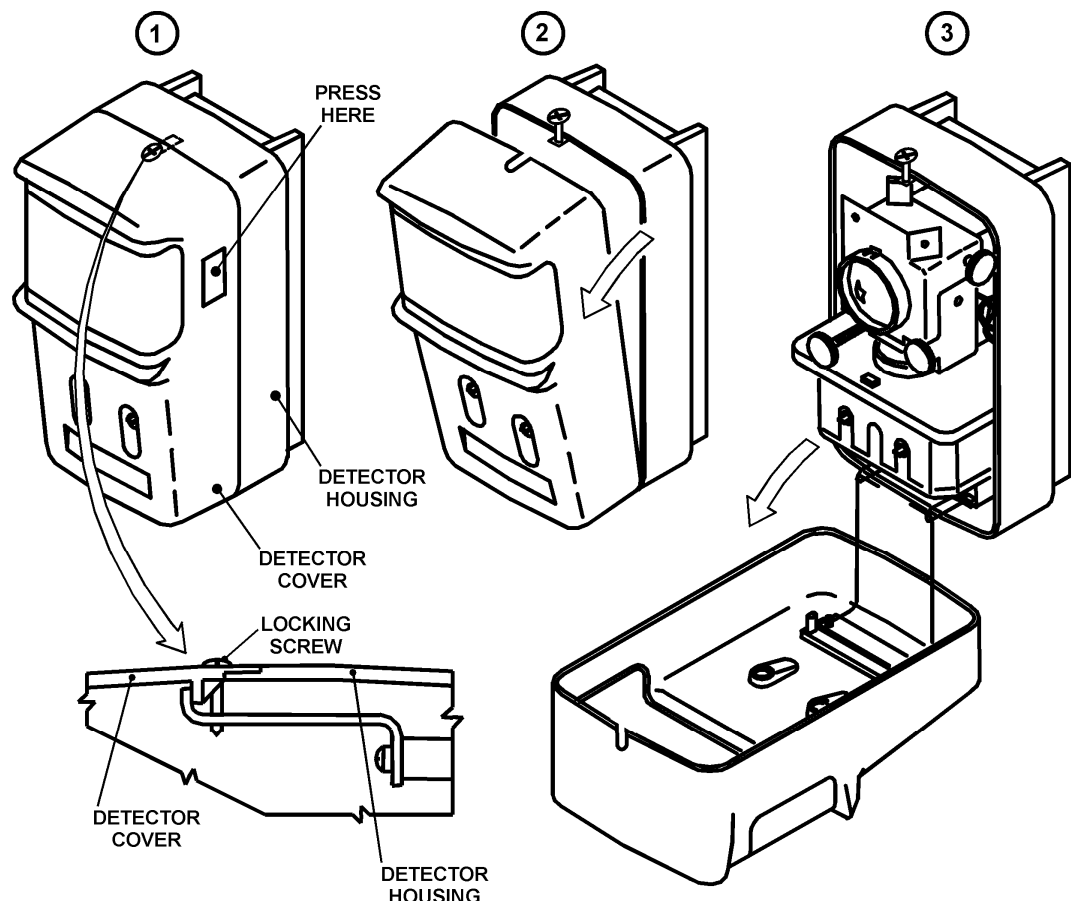

Fig.2

The Receiver can then be mounted onto the Interface kit by aligning the four mounting slots on the rear of the Receiver with the four mounting hooks on the mounting bracket and then sliding the Receiver down gently until it clicks into place.

The Beam Detector can now be aligned. The covers on both the Emitter and Receiver need to be open. The green polling LED on the Receiver should be flashing once every 3 seconds, but please note the units require between 30 and 60 seconds to fully power-up.

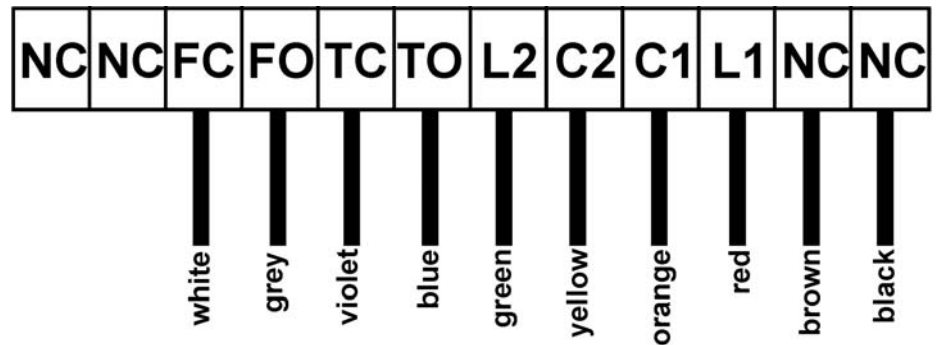

Fig.3

On the top right of the Receiver there is a sight hole, when looking through this the Emitter should be clearly visible via a small mirror at the back of the Receiver (please refer to Fig.4.).

If it isn't, then using the silver alignment wheels (left wheel horizontal adjustment, right wheel vertical adjustment) the Receiver should be adjusted until the Emitter is clearly visible.

This procedure should then be repeated at the Emitter end. Set the distance switch on the emitter according to the monitoring distance required, 5m – 35m SW1 On, SW2 Off, 20m – 100m SW1 Off, SW2 Off. Close the cover, then fasten the locking screw. Please refer to Fig.5.

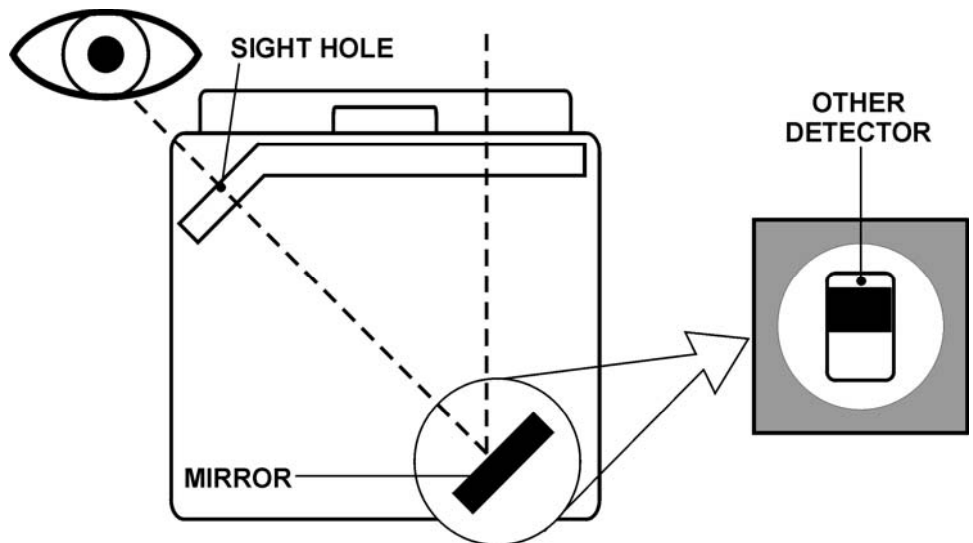

Fig.4

Once complete the 4-way DIL switch on the Receiver needs to be set. Bits 1 and 2 are set according to which signal strength is required; there are three choices available, 25%, 50% and 60%.

Bit 3 can be set to allow the SPC-ET to indicate fault and fire (OFF), or fault only (ON) on a total obscuration of the Beam. Bit 4 can be set to allow automatic reset (OFF) or manual reset (ON) from a fault condition.

The cover on the Receiver can now be closed (please refer to Fig.5.), this should be done carefully, avoiding the possibility of moving the SPC-ET out of alignment. Closing the cover on the receiver synchronises the receiver with the emitter, and then automatically calibrates the signal strength. While synchronisation is being established with the emitter and while the signal strength is automatically adjusted, the monitor LED (green) and fault LED (yellow) on the receiver flash at intervals of three seconds.

If the SPC-ET calibrates successfully, the yellow LED will stop flashing and the green LED will continue to flash once every 3 seconds. It takes about two minutes for fire monitoring to begin after the receiver cover is closed. During this time, care should be taken not to block the beam. Once this has completed the cover should be locked in place with the supplied locking screw (please refer to Fig.5).

After the SPC-ET has completed its initialisation it should be tested using the filters supplied. The range 1 filter relates to 25%, the range 2 filter relates to 50% and the range 3 filter relates to 60%. Firstly place the no alarm side of the filter in front of the SPC-ET for at least one minute this should cause no fire or fault signals, if a fault occurs the amber LED will flash once every 3 seconds. Next place the alarm side of the filter in front of the SPC-ET for at least one minute. During this time a fire alarm should occur and the red LED should illuminate continuously, if no alarm occurs, then the SPC-ET is not operating as expected.

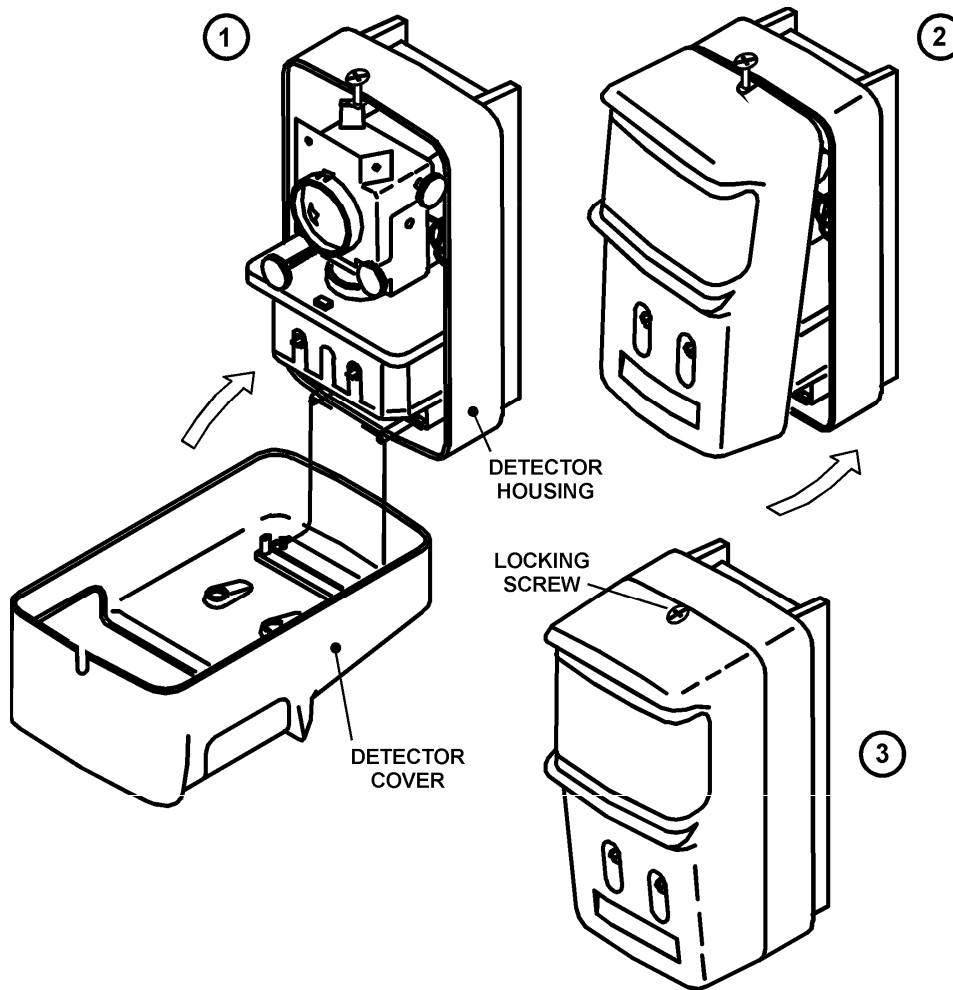

Fig.5

Installation Data

Allowable Misalignment Angle	
Emitter	± 0.5° (max)
Receiver	± 1.0° (max)

Guide Settings

Range	Sensitivity
5 ~ 10m	25% (1.25 dB)
10 ~ 70m	50% (3.01 dB)
70 ~ 100m	60% (3.98 dB)

Approved Settings

The SPC-ET is EN54-12:2002 approved at 25% and 50% sensitivity settings.



Hochiki Europe (UK) Ltd
 Grosvenor Road, Gillingham Business Park,
 Gillingham, Kent, ME8 0SA, England
 Telephone: +44(0)1634 260133 Facsimile: +44(0)1634 260132
 Email: sales@hochikieurope.com
 Web: www.hochikieurope.com

Hochiki Europe (UK) Ltd. reserves the right to alter the specification of its products from time to time without notice. Although every effort has been made to ensure the accuracy of the information contained within this document it is not warranted or represented by Hochiki Europe (UK) Ltd. to be a complete and up-to-date description. Please check our web site for the latest version of this document.