



Instructions

95-8465-02

Unitized Ultraviolet Flame Detector/Controller
U7602E

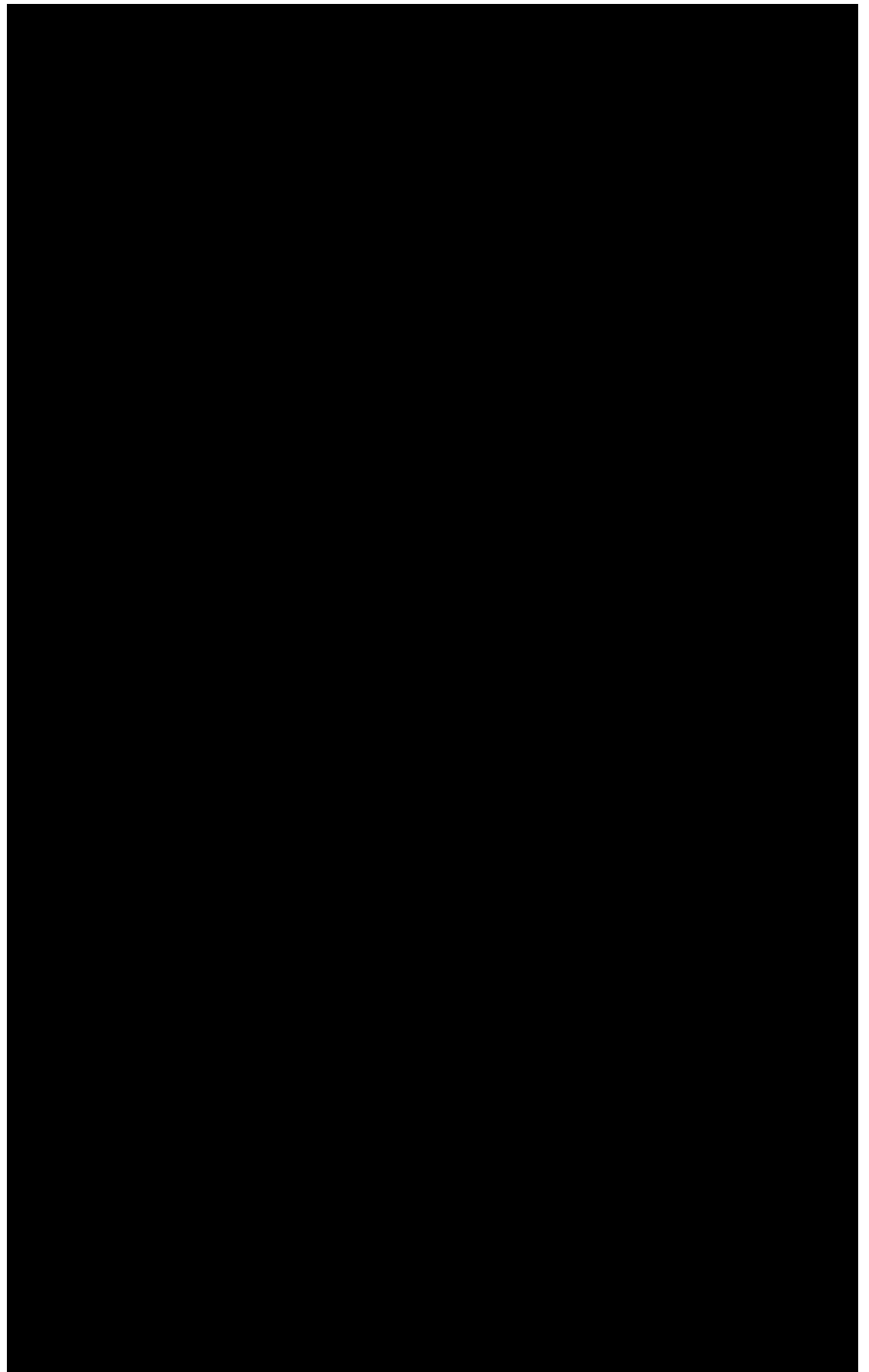

Table of Contents

DESCRIPTION.....	1
GENERAL APPLICATION INFORMATION	2
INSTALLATION.....	3
Detector Positioning	3
Wiring Requirements	3
Wiring Procedure.....	4
SWITCH SETTING PROCEDURE.....	6
ELECTRONIC MODULE INSTALLATION	9
STARTUP PROCEDURE.....	9
Fire Alarm Test.....	9
False Alarm Test	10
TROUBLESHOOTING	10
PERIODIC CHECKOUT PROCEDURE	10
MAINTENANCE	10
REPLACING A DETECTOR MODULE	11
FEATURES	11
SPECIFICATIONS	11
REPLACEMENT PARTS	14
DEVICE REPAIR AND RETURN	14
ORDERING INFORMATION.....	14
Accessories	14
Replacement Parts	14
APPENDIX A.....	15
APPENDIX B.....	18

List of Illustrations

Figure 1	Detector Orientation Relative to Horizon	3
Figure 2	U7602E Detector Assembly.....	4
Figure 3	Cover Locking Devices	4
Figure 4	Location of Terminal Strips Inside Bulkhead	5
Figure 5	U7602E Terminal Configuration.....	5
Figure 6	A Typical System	6
Figure 7	Detector Wired for Non-Isolated 4 to 20 ma Current Output (Sourcing).....	6
Figure 8	Detector Wired for Isolated 4 to 20 ma Current Output (Sinking)	6
Figure 9	Electronic Module Mounted Inside Bulkhead	7
Figure 10	Detector Viewing Window	9
Figure 11	U7602E Detector Cone of Vision	12
Figure 12	Dimensions of U7602E in Inches (Millimeters)	13
Figure 13	Dimensions of Mounting Bracket in Inches (Millimeters)	13
Appendix B	U7602E/U7698E Detector/Apollo Module Style D (Class "A") Wiring Diagram	
Appendix B	Apollo Module DIP Switch Setting	

List of Tables

Table 1	UV Absorbing Gases and Vapors.....	2
Table 2	Switch Setting Table	7
Table 3	U7602E Detector Status/Indications	9
Table 4	Troubleshooting Guide.....	10
Table 5	U7602E Typical Response Distance When Set on Very High	12



Unitized Ultraviolet Flame Detector/Controller

U7602E

IMPORTANT

Be sure to read and understand the entire instruction manual before installing or operating the flame detection system.

WARNING

Do not open the detector assembly in a hazardous area when power is applied.

CAUTION

The wiring procedures in this manual are intended to ensure proper functioning of the device under normal conditions. However, because of the many variations in wiring codes and regulations, total compliance to these ordinances cannot be guaranteed. Be certain that all wiring complies with the NEC as well as all local ordinances. If in doubt, consult a qualified official before wiring the system. Installation must be done by a properly trained person.

CAUTION

To prevent unwanted actuation, alarm and extinguishing devices must be disconnected prior to performing detection system tests.



by red LEDs that are visible through the detector's viewing window. For product certification details, reference the Specifications Section.

DATA LOGGER

The optional data logger provides status recording capability for the detector. Important status data such as power-up/down, faults and alarms are date and time stamped as they occur and stored in non-volatile memory. Up to 510 events can be recorded — up to 63 fire alarm events and up to 447 non-fire events. This data is later uploaded to a personal computer (PC) where it can be displayed, saved and/or printed.

The Data Logger system consists of a special electronic module (located inside the detector enclosure) and a W6300 Detector Inspector™, which provides the interface between the electronic module and the PC.

The W6300 Detector Inspector is furnished with an RS-232 serial port for connection to the serial port of the PC. Communication between the data logger module and the PC uses the Modbus RTU protocol, with the data logger module configured as a Modbus slave.

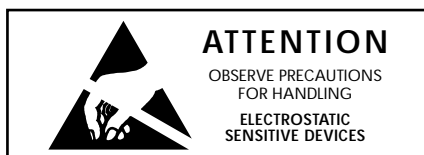

DESCRIPTION

The U7602E is a unitized ultraviolet (UV) flame detector, containing a UV sensor module and control circuitry in an explosion-proof enclosure. The detector is equipped with both automatic and manual **oi** test capability. Standard outputs include fire and fault relays, and an optional 4 to 20 ma output. Field selectable options include latching/non-latching relays, sensitivity, time delay and arc rejection. Operating status is indicated

***oi** is Detector Electronics' Trademark for its patented Optical Integrity Systems, U.S. Patent 3,952,196, United Kingdom Patent 1,534,969, Canada Patent 1,059,598.

Table 1—UV Absorbing Gases and Vapors

The following 38 substances exhibit significant UV absorption characteristics. These are also generally hazardous vapors. While usually of little consequence in small amounts, these gases can restrict UV detection if they are in the atmosphere in heavy concentrations. It should also be determined whether or not large amounts of these gases may be released as a result of a fire-causing occurrence.

Acetaldehyde	Methyl Methacrylate
Acetone	Alpha-Methylstyrene
Acrylonitrile	Naphthalene
Ethyl Acrylate	Nitroethane
Methyl Acrylate	Nitrobenzene
Ethanol	Nitromethane
Ammonia	1-Nitropropane
Aniline	2-Nitropropane
Benzene	2-Pentanone
1,3 Butadiene	Phenol
2-Butanone	Phenyl Glycide Ether
Butylamine	Pyridine
Chlorobenzene	Hydrogen Sulfide
1-Chloro-1-Nitropropane	Styrene
Chloroprene	Tetrachloroethylene
Cumene	Toluene
Cyclopentadiene	Trichloroethylene
O-Dichlorobenzene	Vinyl Toluene
P-Dichlorobenzene	Xylene

If UV-absorbing gases may be a factor in a given application, precautionary measures should be taken. Detectors can be placed closer to the potential hazard area, and/or the sensitivity of the detection system can be increased. Contact the factory for further details.

Substances such as methane, propane, butane, camphor, hexane and octane are not UV absorbing.

The Inspector software (included) can operate on most Intel® Pentium® based computers running Microsoft Windows 95/98.

The real time clock in the module is furnished with battery back-up to ensure correct operation in the event of a power failure. The clock provides second, minute, hour, day, month and year data.

The detector's relays and LEDs function exactly the same as the standard detector; however, the 4 to 20 ma output is not available.

GENERAL APPLICATION INFORMATION

In applying any type of sensing device as a fire detector, it is important to know of any conditions that can prevent the device from responding to a fire, and also to know what other sources besides fire will cause the device to respond.

Windows

Glass and plexiglas windows significantly attenuate UV radiation and **must not** be located between the detector and a potential flame source. If the window cannot be eliminated or the detector location changed, contact Detector Electronics for recommendations regarding window materials that will not attenuate UV radiation.

Obstructions

Environmental contaminants such as dust, dirt and other films will attenuate UV radiation and should not be allowed to accumulate on the detector viewing window. In addition, physical obstructions that can block the detector's view must not be allowed to come between the detector and the protected hazard. It should also be noted that certain gases or vapors absorb significant amounts of UV and can adversely affect the detector's response time. See Table 1 for a list of UV absorbing gases.

Smoke

Smoke will absorb UV radiation. In applications where accumulations of dense smoke can be expected to precede the presence of flame, ultraviolet detectors that are used in enclosed areas should be mounted on the wall approximately 3 feet (1 meter) from the ceiling where the accumulation of smoke is reduced.

Arc Welding

Electric arc welding is a source of intense ultraviolet radiation, and care must be taken to ensure that arc welding is not performed in the protected area without securing the fire detection system. UV radiation from arc welding readily scatters and can deflect across significant distances, even when direct obstructions exist. Any open door or window can allow nuisance UV radiation from arc welding to enter an enclosed area.

When x-rays or radioactive substances are present in the area being protected, the UV system must be disabled until those sources are removed.

Common Environmental Conditions

The detector is not affected by environmental conditions such as wind, rain or extremes of temperature and pressure. It is also insensitive to the ultraviolet component of solar radiation.

UV radiation generated by periodic lightning or sparks in the area can be effectively ignored by the detector using the arc rejection feature or the fire relay time delay.

UV detectors should not be positioned so that their cone of vision can scan the horizon. Rather, they should be directed down over the designated hazardous area to reduce the likelihood of picking up UV radiation from distant sources.

INSTALLATION

DETECTOR POSITIONING

Detectors should be positioned to provide the best unobstructed view of the area to be protected. The following factors should also be taken into consideration:

- Identify all high risk fire ignition sources.
- Be sure that enough detectors are used to adequately cover the hazardous area.
- Locate and position the detector so that the fire hazard(s) are within both the field of view and detection range of the device. Refer to Appendix A for specific information.
- Be sure that the unit is easily accessible for cleaning and other periodic servicing.
- Particular attention should be paid to potential false alarm sources in the area.
- For outdoor applications, the detector should be aimed downward at least 10 to 20 degrees to prevent it from scanning the horizon. This minimizes response to distant UV sources outside the protected area. See Figure 1.
- Dense fog, rain or ice will absorb UV radiation and reduce the sensitivity of the detector.
- If smoke is expected before flame, it is recommended that smoke or other detectors be used in addition to the U7602E.

If possible, fire tests should be conducted to verify correct detector positioning and coverage.

WIRING REQUIREMENTS

Wire Size and Type

The system should be wired using a 14 to 22 gauge (1.3 to 0.5 mm²) cable. The wire size selected should be based on the number of detectors connected, the supply voltage and the cable length. An input voltage of **18 vdc minimum must be present at the detector** to ensure proper operation.

The use of shielded cable is highly recommended to protect against interference caused by EMI and RFI. When using cables with shields, the shield should be insulated at the detector and connected to earth ground only at the control panel.

In applications where the wiring cable is installed in conduit, the conduit should not be used for wiring to other electrical equipment.

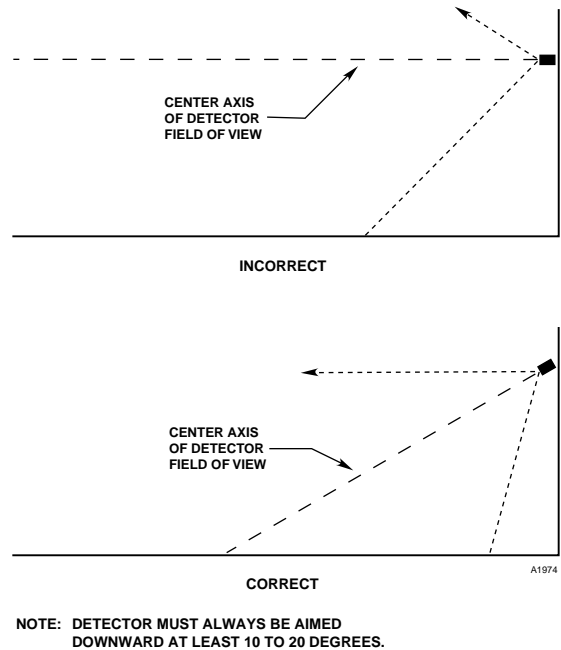

Figure 1—Detector Orientation Relative to Horizon

Protection Against Moisture Damage

Conduit systems are never completely air-tight. As a result, significant amounts of condensation can form within the conduit system. Since moisture can have a detrimental effect on electronic equipment, it is important to take proper precautions during installation to ensure that moisture will not come in contact with the electrical connections or components of the system.

Conduit drains must be installed at water collection points to automatically drain accumulated moisture. Conduit breathers should be installed at upper locations to provide ventilation and allow water vapor to escape. At least one breather should be used with each drain.

Conduit raceways should be inclined so that water will flow to low points for drainage and will not collect inside enclosures or on conduit seals. If this is not possible, install conduit drains above the seals to prevent the collection of water or install a drain loop below the detector with a conduit drain at the lowest point of the loop.

Explosion-proof conduit seals should be installed within 18 inches (46 cm) of the detector. Conduit seals prevent the passage of vapors or flames through the conduit. Seals are recommended even if they are not required by local wiring codes.

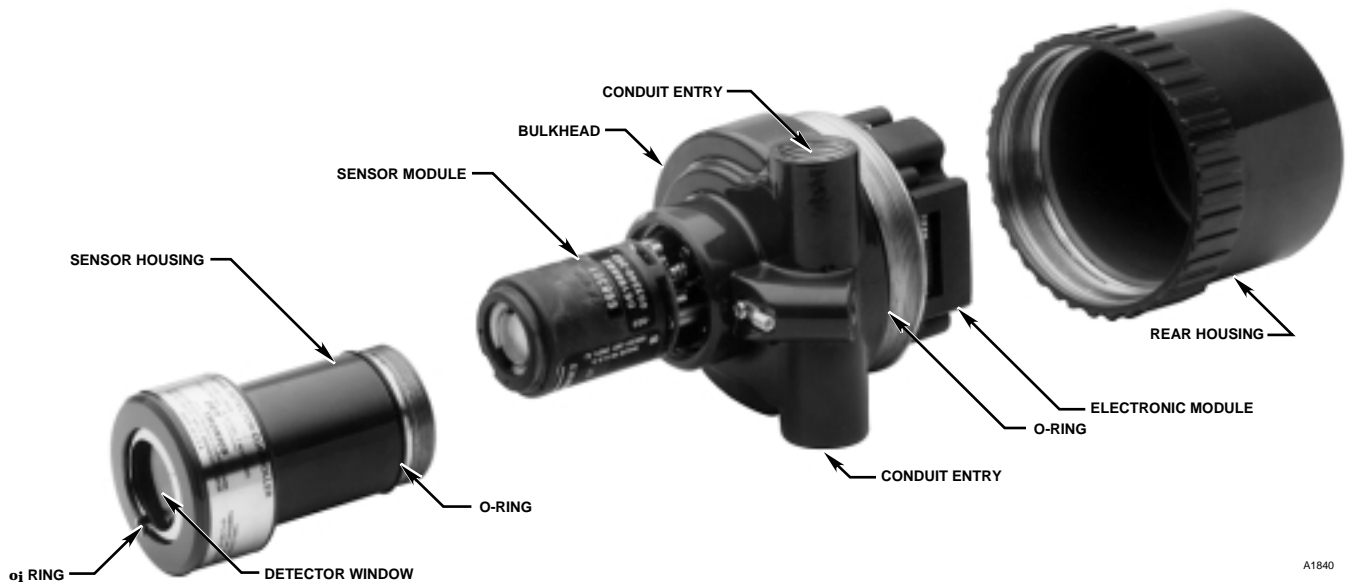

A1840

Figure 2—U7602E Detector Assembly

When using steel wire armored or mineral-insulated copper-sheathed cable, select an approved gland with a watertight compression stage and an overall gland shroud for outdoor applications. A sealing washer must be fitted between the gland and the conduit/cable entry to ensure IP66 rating.

WIRING PROCEDURE

The following procedure should be used for mounting and wiring the detector.

1. Remove the sensor housing from the bulkhead (turn counterclockwise). Install the sensor module and replace the sensor housing. See Figure 2.

NOTE

If the detector is equipped with a cover locking device, it must be loosened using a hexagonal (Allen) wrench (see Figures 3A and 3B).

2. Mount the swivel mounting bracket using 1/4 inch (M6) screws with a length of at least 1 inch (25 mm). The mounting surface should be free of vibration. Allow adequate space around the swivel to facilitate aiming and wiring of the detector. Armored flexible conduit should be used for the final 3 feet (one meter) of the cable run to allow for aiming and alignment of the detector.

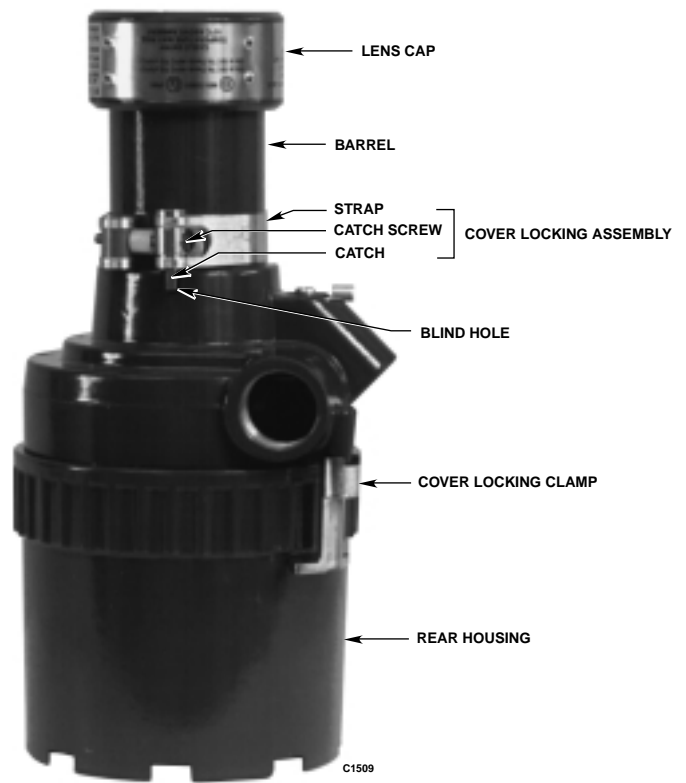

C1509

Figure 3A—Cover Locking Devices

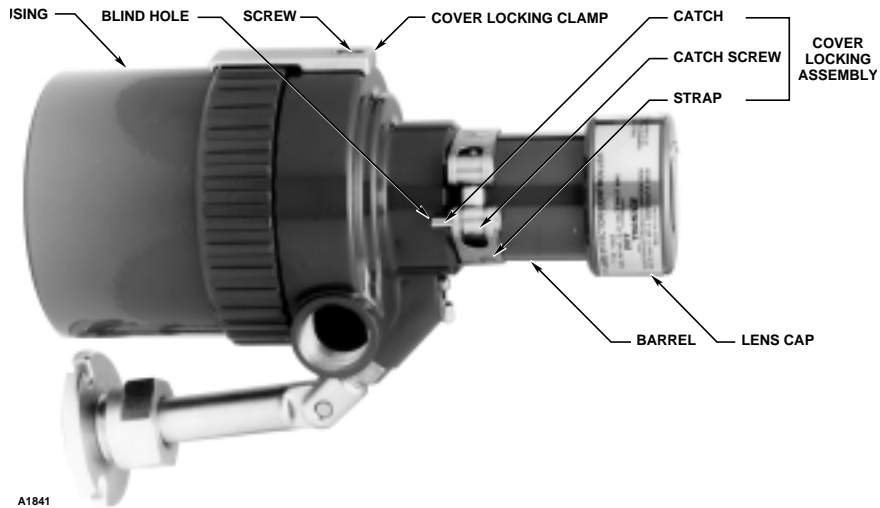

Figure 3B—Cover Locking Devices

3. Attach the detector to the swivel mounting bracket.
4. Remove the rear housing from the bulkhead (turn counterclockwise).
5. Connect the wires to the appropriate screw terminals on the terminal block. Refer to Figures 4 through 8.
6. Install any optional accessories (such as air shields).
7. Set the rocker switches on the DIP switch assembly on the electronic module. Refer to "Switch Setting Procedure" below.

NOTE

Connect the shield to power supply minus (circuit ground) at the detector end. At the fire panel end, connect the shield and power supply minus to chassis ground through a 0.47 μ F 400 Volt non-polarized capacitor (not supplied).

NOTE

When installing the U7602E with Apollo module, refer to Appendix B for a wiring diagram and switch setting information.

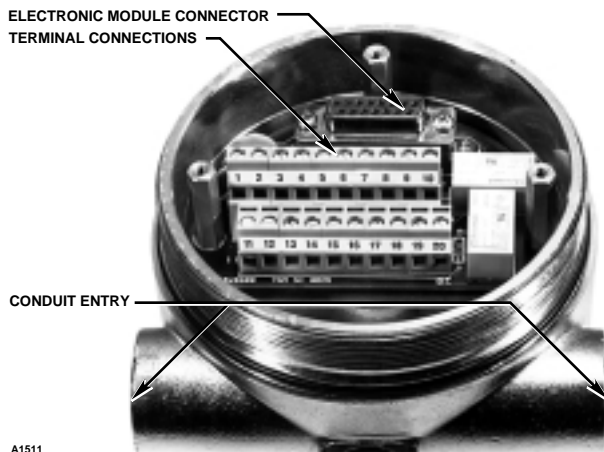
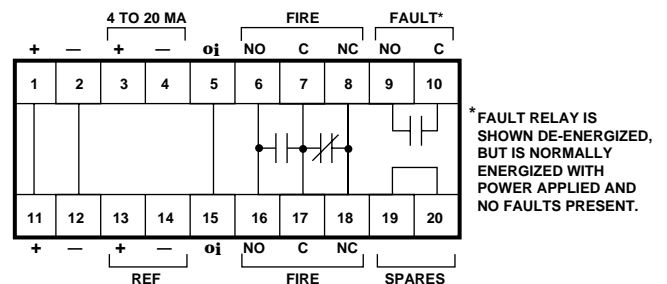

Figure 4—Location of Terminal Strips Inside Bulkhead



NOTES:

1. INPUT VOLTAGE IS 18 TO 32 VDC.
2. FOR MANUAL oi, CONNECT A NORMALLY OPEN SWITCH (CAPABLE OF SWITCHING 4 MA AT 32 VDC AND WITH RESISTANCE NO MORE THAN 25 OHMS) BETWEEN THE NEGATIVE (-) SIDE OF THE DC POWER SOURCE AND TERMINAL "5" OR "15" ON THE DETECTOR TERMINAL BLOCK. EACH DETECTOR SHOULD HAVE ITS OWN oi TEST SWITCH.
3. RELAY CONTACTS RATED 5 AMPERES RESISTIVE AT 30 VDC.
4. CONNECT THE SHIELDS TO EARTH GROUND AT THE POWER SOURCE. DO NOT GROUND THE SHIELD AT THE DETECTOR HOUSING (UNLESS REQUIRED BY LOCAL CODES).

A1842

Figure 5—U7602E Terminal Configuration

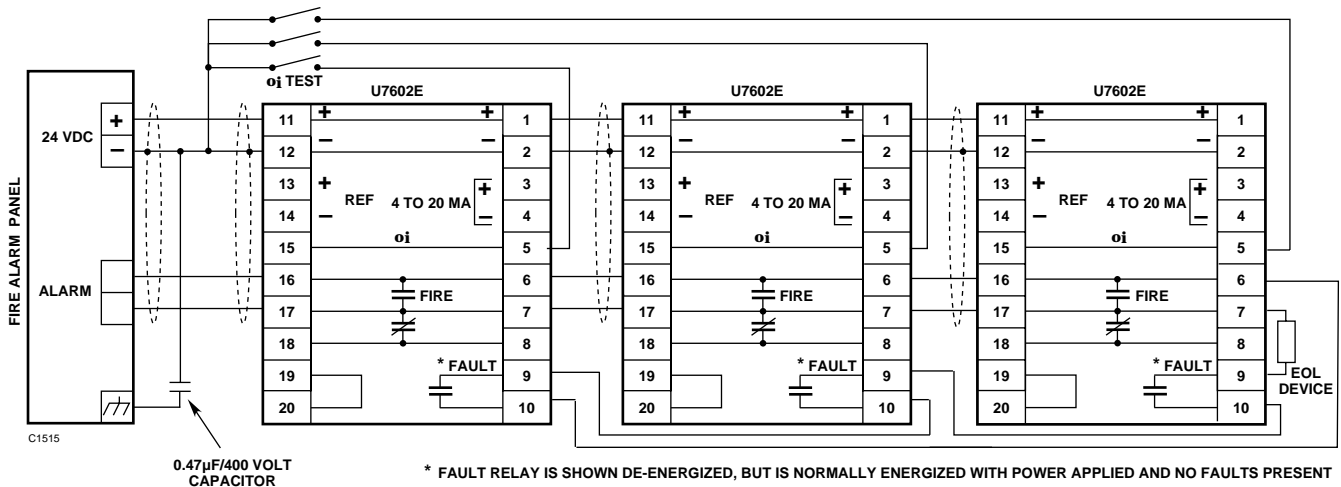

Figure 6—A Typical System

SWITCH SETTING PROCEDURE

Before the electronic module can be installed, the DIP switches on the module must be set. Refer to Figure 9 for location of switches and Table 2 for switch positions and functions. Switch is "off" when switch position is toward the circuit board.

Set the switches as desired, then record the switch settings for future reference.

IMPORTANT

Proper configuration is vital to successful application. Configuration determines the balance between false alarm resistance and flame sensitivity. Use of excess sensitivity may result in false alarms, while too little sensitivity may cause target fires to be missed. Use of arc rejection is recommended except when extremely high speed response is required.

SW-1 Operating Mode

The operating mode determines the type of logic that the UV flame detector will use for processing fire signals (either standard or arc rejection).

Standard Mode

In the standard processing mode, the detector output (measured in counts per second) is compared to the fire threshold (the "sensitivity" setting as described below). If the radiant energy level from the fire exceeds the selected alarm threshold level, the time delay begins (if a time delay is selected). If the radiant energy level from the fire remains above the selected sensitivity level for the duration of the time delay, the fire alarm output is activated. In every application, it is crucial to ensure that the radiant ultraviolet energy level from the expected fire at the required distance from the detector will exceed the selected sensitivity level.

Standard signal processing is recommended for applications where background electrostatic energy has been verified to be absent.

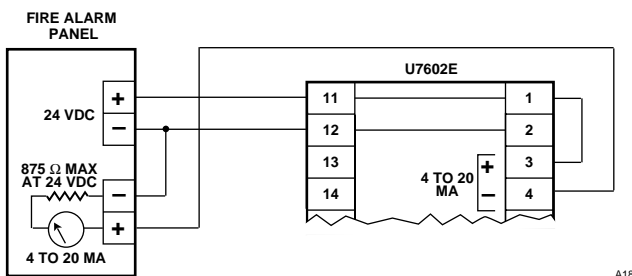

Figure 7—Detector Wired for Non-Isolated 4 to 20 ma Current Output (Sourcing)

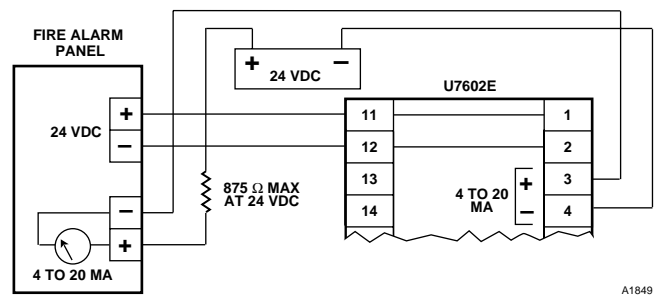

Figure 8—Detector Wired for Isolated 4 to 20 ma Current Output (Sinking)

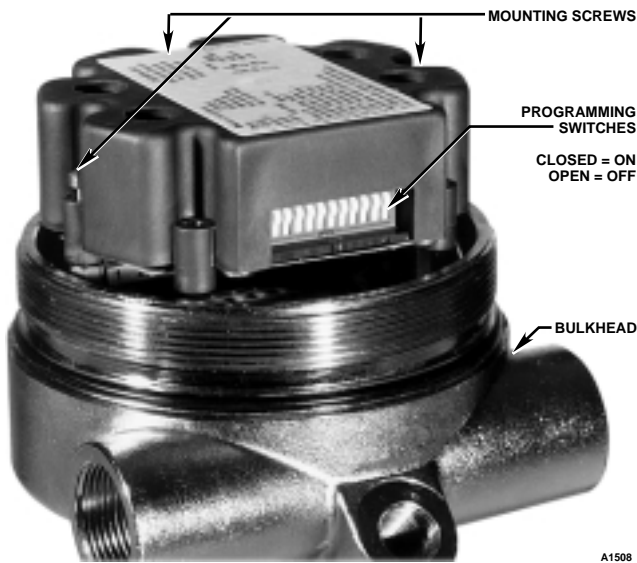

Figure 9— Electronic Module Mounted Inside Bulkhead

Arc Rejection Mode

The arc rejection mode enables the detector to prevent nuisance fire alarms caused by UV from short-duration electrical arcs or electrostatic discharge, while maintaining the ability to reliably detect the UV given off by a flame. The arc rejection mode is not recommended unless these false alarm sources are present within the application to be protected. Typical applications that benefit from arc rejection logic include electrostatic coating processes and uncontrolled environments where transient UV sources can be present, such as many typical outdoor applications.

The arc rejection algorithm examines the radiant energy level detected within a specified unit of time (timed gate). The output of the detector is determined by three variables:

- sensitivity level
- gate length
- number of consecutive gates required.

Table 2—Switch Setting Table

Switch	Function	Closed (On)	Open (Off)
1	OPERATING MODE	Arc Rejection (No High Speed)	Standard (with High Speed)
2	oi	Manual	Automatic
3	FIRE RELAY	Non-latching	Latching
4	FAULT RELAY	Non-latching	Latching
5	NOT USED		
6,7	ARC REJECTION LOGIC (SW-1 closed)		
	Switch No.	Arc Rejection Level	Consec. Gates
	6	7	Time (seconds)
			Min. Processing Time (seconds)
	Open	Open	Very High
	Open	Closed	High
	Closed	Open	Medium
	Closed	Closed	Low
			8
			4
			4
			4
			1/16
			1/16
			1/8
			1/4
			0.5
			0.25
			0.5
			1.0
8,9	SENSITIVITY		
	Switch No.	Sensitivity Setting	Relative Threshold Equivalent in CPS
	8	9	
	Open	Open	Very High
	Open	Closed	High
	Closed	Open	Medium
	Closed	Closed	Low
			10 cps
			25 cps
			50 cps
			100 cps
10 to 12	TIME DELAY		
	Switch	Duration (seconds)	
	10	4	Total duration is value of all closed switches added together.
	11	2	No high speed output if time duration is used.
	12	1	Time delay with all switches open = 0 second

Different combinations of these variables allow for various levels of transient arc rejection capability. There are four arc rejection levels (very high, high, medium, and low) that are selectable for each detector (SW- 6 and 7). Refer to Table 2.

The proper arc rejection setting for a given application must be determined through testing. For indoor applications with known electrostatic energy fields within 15 feet of the detector, an arc rejection setting of “very high” or “high” is typical. For outdoor applications, “medium” or “low” arc rejection settings are typical.

It is recommended that each detector be thoroughly tested at the programmed arc rejection setting within the ambient conditions that will be present during normal operation. This will help to ensure that the selected arc rejection setting is proper for the application.

Close SW-1 to select arc rejection logic. Place SW-1 in the open position for standard fire detection.

SW-2 Automatic or Manual **oi**

The **o**i system uses an internally generated UV test signal to determine the relative condition of the detector and its optical surfaces.

If automatic **o**i testing is selected, the **o**i test is automatically performed once every minute. The automatic **o**i test does not actuate the alarm relay or interfere with normal detector operation.

The manual **o**i test is initiated using an externally wired switch. A successful manual **o**i test activates the alarm relay and current loop. The manual **o**i test can be used in addition to automatic **o**i to verify operation of the fire relay, LEDs and field wiring.

Close switch to turn off automatic **o**i.

SW-3 Fire Relay Latching

When latching operation is selected, the fire relay is reset by removing input power for a minimum of 0.1 second.

SW-4 Fault Relay Latching

If the fault relay is set for latching, the fault will not clear until it is corrected and the

unit is reset. If a fire occurs, the unit will indicate a fire, over-riding the fault condition. If a fault is still present after the fire has been extinguished, the unit will again indicate a fault until the problem has been corrected and the unit is reset.

SW-5 Not used

SW-6,7 Select Level of Arc Rejection (SW-1 closed)

The “very high” and “high” levels are typically used in indoor applications. The “medium” and “low” levels are typically used in outdoor applications. These switches have no effect when standard signal processing is selected.

SW-8,9 Sensitivity

These switches affect the sensitivity of the detector in both standard and arc rejection modes. The selected sensitivity level determines the fire alarm threshold setpoint. The higher the sensitivity level, the greater the detection range, but the possibility of false alarms will be increased.

Four sensitivity levels are selectable. The sensitivity setting **must** be appropriate for the anticipated fire size at the required distance from the detector.

SW-10 to 12 Time Delay

Standard Mode

The fire relay is actuated only if the fire signal exceeds the sensitivity setting for the entire duration of the programmed time delay.

Arc Rejection Mode

If the fire signal meets the programmed arc rejection requirements, the time delay begins. The fire relay is actuated if the fire signal continues for the duration of the time delay.

NOTE

If the switch settings are ever changed, power to the unit must be cycled before those changes will take effect.

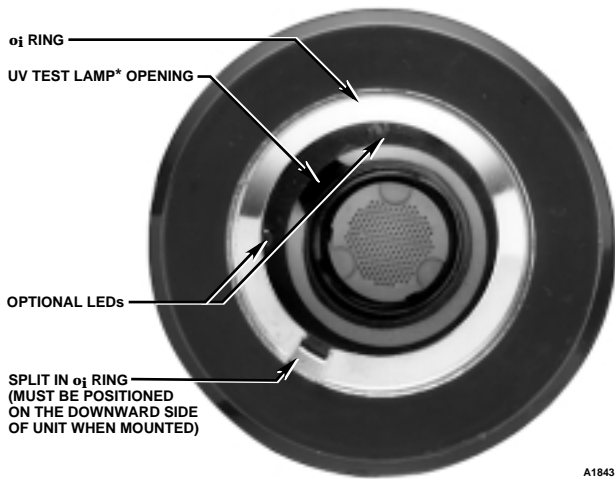

A1843

* UV TEST LAMP OPENING MUST NOT BE ALIGNED WITH SPLIT IN o1 RING

NOTE: o1 RING NOT USED WITH INTERNAL REFLECTION MODEL.

Figure 10— Detector Viewing Window

- A) the **o1** source (UV test lamp) is located on top
- B) the split in the **o1** reflective ring is not aligned with the UV test lamp on the detector module
- C) the split in the **o1** ring is directed downward to prevent a buildup of contaminants between the **o1** ring and the viewing window.

- 6. Clean the viewing window and **o1** ring using the procedure described in the “Maintenance” section.

STARTUP PROCEDURE

When installation of the equipment is complete, the fire alarm and false alarm tests should be performed.

Table 3 indicates the condition of the Fire relay, Fault relay, optional 4 to 20 ma output and LEDs for each detector status.

ELECTRONIC MODULE INSTALLATION

1. Ensure that the switch settings on the module are correct and that the wiring to the detector is correct.
2. Install the electronic module, ensuring that the connector is aligned correctly. Tighten the three captive screws that hold the electronic module in place. See Figures 2 and 9.
3. Replace the rear housing and hand tighten to ensure proper sealing.
4. Aim the detector at the potential hazard and tighten the swivel nut.
5. Check the viewing window surface (Figure 10) and ensure that:

FIRE ALARM TEST

1. Disable any extinguishing equipment that is connected to the system.
2. Apply input power to the system. Allow a one second power-up delay.

NOTE

The Fault Relay does not energize until after the power-up delay is complete.

3. Be sure that the detector viewing window and **o1** ring are clean and that the **o1** ring is properly installed.
4. Optional accessories (such as air shields) should be installed before the test is performed.

Table 3—U7602E Detector Status/Indications

Status	LEDs	Optional 4 to 20 ma Output*	Fire Relay	Fault Relay
Normal with automatic o1 selected	Blink every 5 seconds	4 ma	De-energized	Energized
Normal with manual o1 selected	Blink every 10 seconds	4 ma	De-energized	Energized
Fault (General)	Off	0 ma	De-energized	De-energized
Power Supply Fault	Off	1 ma	De-energized	De-energized
o1 Fault	Off	2 ma	De-energized	De-energized
UV being detected, but time delay not yet satisfied	LEDs continue blinking	16 ma	De-energized	Energized
Fire (relay actuated)	On	20 ma	Energized	Energized

* Fire signal always takes priority on the current loop.

5. Hold a UV source (such as the W8066) within the cone of vision of the detector at a distance relative to the selected detection range or press the **oi** test button for 5 to 10 seconds (or until an alarm is generated) — the alarm relay energizes and the LEDs are illuminated.

Lack of response may indicate reduced sensitivity due to contamination on the viewing window, a damaged sensor, or electronic circuitry or wiring problems. Refer to “Troubleshooting” for additional information.

6. Remove the UV source (or release the **oi** test button). If the unit is programmed for non-latching operation, the alarm relay will become de-energized and the LEDs will turn off when the UV source is removed. If the unit is programmed for latching operation, it can be reset by removing input power (0.1 second minimum).
7. Repeat this test for all detectors in the system.
8. Verify that all detectors are properly aimed at the area to be protected.
9. Enable extinguishing equipment when the test is complete.

FALSE ALARM TEST

1. Disable all alarm response equipment.
2. Allow the system to monitor the protected area for a period of time with all the normal operations in the area taking place. If the detector responds (indicating a fire when no fire has occurred), check the area to see if UV sources are present. If possible, remove the sources, or reposition the detector so that the sources fall outside the cone of vision. If problems still occur, adjust the time delay, sensitivity or arc rejection settings.

The model U7656 Hand-Held UV Monitor is available from Detector Electronics for conveniently scanning the protected area to verify the presence and to identify the source of UV radiation.

3. Recycle power and test again as described above.
4. Once the correct settings are obtained, turn on all alarm and extinguishing equipment that is connected to the system. Record all switch settings for future reference.

TROUBLESHOOTING

Table 4 is intended to serve as an aid in locating the cause of a system malfunction. If the problem cannot be corrected, contact the factory for assistance.

PERIODIC CHECKOUT PROCEDURE

To ensure reliable protection, the system should be tested **on a regularly scheduled basis** using manual **oi**, a live flame, or other UV source such as the W8066.

To test the system, perform the “Fire Alarm Test” as described in the “Startup Procedure” section of this manual.

MAINTENANCE

The detector requires no periodic calibration. However, to maintain maximum sensitivity, the viewing window must be kept clean at all times.

To clean the optical surfaces, remove the **oi** ring from the detector by gently squeezing the tabs together and then pulling out. Clean the viewing window and the back side of the **oi** ring using a clean cloth or tissue and Det-Tronics window cleaning solution. Avoid the use of commercial glass cleaners, since many of them

Table 4—Troubleshooting Guide

Symptom	Possible Cause
LEDs are not blinking and Fault Relay is activated (de-energized)	Dirty viewing window. oi ring dirty, misaligned or missing. Input voltage too low or too high. Open, shorted or incorrect wiring.
No response to fire stimuli or to manual oi test	Dirty viewing window. Insufficient supply voltage. Open, shorted or incorrect wiring. Defect in UV module. Defect in electronic module.

leave a UV absorbing residue on the surface of the window. Avoid leaving fingerprints on the reflective surface of the **oij** ring. Re-install the ring so that the opening is positioned downward.

NOTE

If corrosive contaminants in the atmosphere cause the reflective rings to deteriorate to the extent that it is no longer possible to restore them to their original condition, they must be replaced.

To ensure the watertight integrity of the detector housing, the O-rings must be in good condition. Periodically, the housing should be opened and the O-rings inspected for breaks, cracks, or dryness. To test the O-rings, remove them from the detector housing and stretch them slightly. If cracks are visible, they should be replaced. If they feel dry to the touch, a thin coating of silicone-free grease should be applied. When re-installing the O-rings, be sure that they are properly seated in the grooves on the housing.

Before re-assembling the detector, apply a thin coating of silicone-free grease to the threads on the detector enclosure. This will both lubricate the threads and help to prevent moisture from entering the detector housing.

REPLACING A DETECTOR MODULE

1. Remove power from the detector and relay contacts.
2. Remove the appropriate section of the sensor housing (see Figure 2).
3. Remove the existing module and install the new module. When replacing an electronic module, note the settings of all switches on the electronic module being replaced, then duplicate those settings on the replacement module. The electronic module is secured inside the housing using three captive screws.
4. Check the condition of the O-ring, then replace the sensor housing.
5. Inspect the viewing window and **oij** ring and clean if necessary.
6. Perform the "Startup Procedure" as described in this manual before returning the system to normal operation.

FEATURES

- Long detection range to gasoline fires.
- Selectable automatic or manual **oij**.
- Fire and fault relays standard.
- Easily visible LEDs indicate normal operation, fire and fault conditions.
- Adjustable sensitivity and time delay for fire output.
- High-speed capability.
- Selectable latching or non-latching for fire and fault outputs.
- Programmable for arc rejection or standard signal processing method.
- Microprocessor based circuitry.
- Optional swivel mounting bracket for ease of installation and positioning.
- Optional Data Logger available.
- Operates under adverse weather conditions and in dirty environments.
- Space provided for installation of addressable interface devices.
- EMI hardened.
- Explosion-proof/flame-proof detector housing designed to meet CENELEC, FM and CSA requirements.

SPECIFICATIONS

OPERATING VOLTAGE—

24 vdc nominal (18 vdc minimum, 32 vdc maximum).

POWER CONSUMPTION—

2.0 watts typical, 4.0 watts maximum during **oij** test, 7.0 watts maximum when end of line components are installed.

OUTPUT RELAYS—

The Fire Alarm relay is Form C (N.O. and N.C. contacts available), normally de-energized and field programmable for either latching or non-latching operation. The Fault relay is normally energized. The Fault relay contacts are normally closed when power is applied and no faults are present. Relay contacts are rated for 5 amperes at 30 vdc.

100% REPRESENTS THE MAXIMUM DETECTION DISTANCE FOR A GIVEN FIRE. THE SENSITIVITY INCREASES AS THE ANGLE OF INCIDENCE DECREASES.

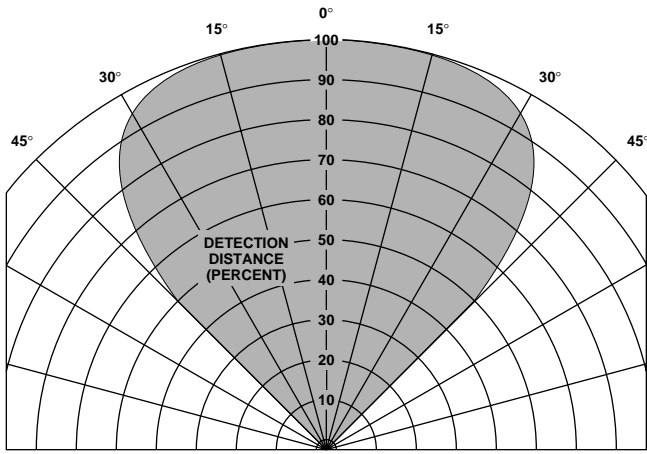

Figure 11—U7602E Detector Cone of Vision

TEMPERATURE RANGE—

Standard Model: -40°F to +167°F (-40°C to +75°C).

High Temperature Model:

-40°F to +257°F (-40°C to +125°C).

Storage: -67°F to +185°F (-55°C to +85°C).

Turbine applications high temperature exposure limited to 3 hour intervals.

HUMIDITY RANGE—

0 to 100% relative humidity.

SPECTRAL SENSITIVITY RANGE—

UV radiation over the wavelength range from 1850 to 2450 angstroms.

CONE OF VISION—

90 degrees, with highest sensitivity along the central axis (gasoline, methane). See Figure 11.

FLAME SENSITIVITY—

The detector has 4 field adjustable sensitivity settings. Refer to Table 5 for response characteristics when the highest sensitivity level is selected.

Table 5—U7602E Typical Response Distance When Set on Very High

Material	Distance	
	Feet	Meters
Gasoline	90	27
Methane	80	24
Diesel	65	20
Methanol	65	20
Acetone	60	18
Toluene	50	15
Wood Shavings (excelsior)	50	15

RESPONSE TIME—

The detector is field selectable for a 0 to 7 second time delay (in 1 second increments).

POWER ON TIME DELAY—

0.5 second.

ENCLOSURE MATERIAL—

Copper-free aluminum or 316 stainless steel. Optional stainless steel mounting bracket used with both housings.

CERTIFICATION—

FMR:

Reference Appendix A.

CSA:

Standard Temperature Version

Class I, Div. 1, Groups B, C and D.

Class I, Div. 2, Groups A, B, C & D (T3C).

Class II/III, Div. 1, Groups E, F and G.

Class II/III, Div. 2, Groups F and G (T3C).

Enclosure Type 4X.

High Temperature Version

Class I, Div. 1, Groups B, C and D.

Class I, Div. 2, Groups A, B, C & D (T3).

Class II/III, Div. 1, Groups E, F and G.

Class II/III, Div. 2, Groups F and G (T3).

Enclosure Type 4X.

CENELEC:

Standard Model:

EExd IIB + H₂ T6 (T_{amb} = -40°C to +75°C)

Extended Temperature Model:

EExd IIB + H₂ T6 (T_{amb} = -40°C to +75°C)

EExd IIB + H₂ T4 (T_{amb} = -40°C to +125°C)

IP66.

Special conditions for safe use—

The detector contains capacitors that could be a source of ignition if the enclosure is opened inside the hazardous area. The enclosure must not be opened, even if isolated when a flammable atmosphere is present.

The cable must only be connected to the enclosure by a flameproof cable entry device certified to EN50 018. If only one cable entry hole is used, the other hole must be closed by a certified flameproof stopping plug.

The flame detector is available in two versions – one for ambient temperatures up to +75°C and one for temperatures up to +125°C. The marking plate will show the actual allowed ambient temperature.

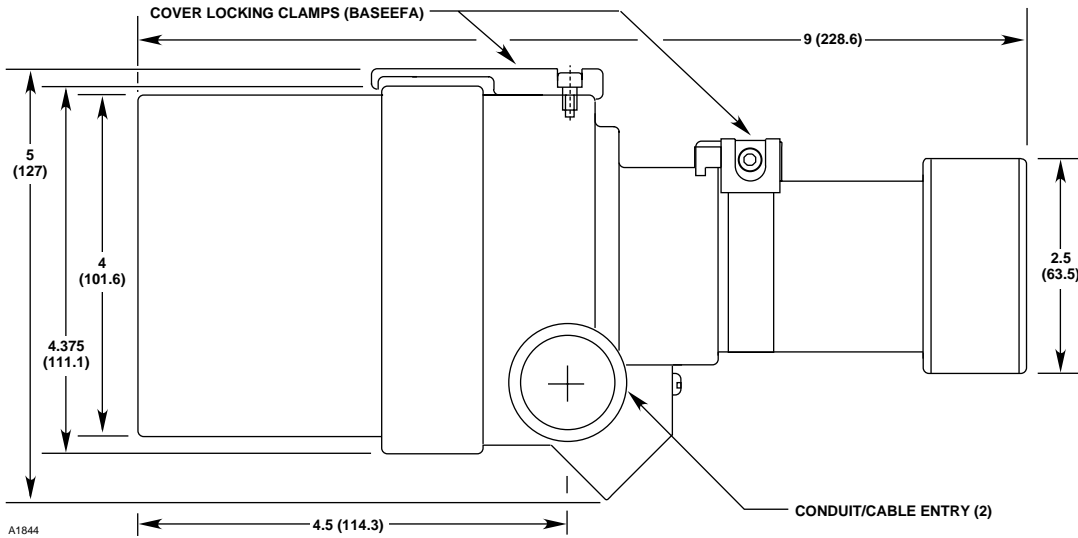

Figure 12—Dimensions of U7602E in Inches (Millimeters)

INGRESS PROTECTION—

NEMA/TYP E 4X (indoor and outdoor use).
IP66.

VIBRATION—

Meets MIL-STD-810C vibration requirements.

DIMENSIONS—

See Figures 12 and 13.

WIRING—

14 AWG (1.5 mm²) to 22 AWG (0.3 mm²) shielded cable is recommended.

CONDUIT ENTRIES—

Two conduit/cable entries per detector. Two sizes available: 3/4 inch NPT or 25 mm.

SHIPPING WEIGHT (APPROXIMATE)—

Aluminum: 4.75 pounds (2.14 kilograms).
Stainless Steel: 10 pounds (4.54 kilograms).

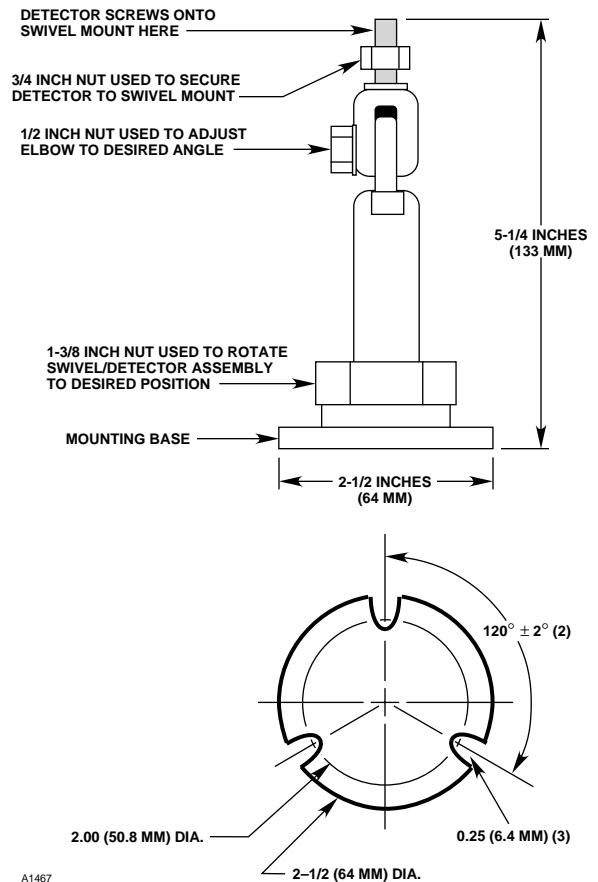

Figure 13—Dimensions of Mounting Bracket in Inches (Millimeters)

REPLACEMENT PARTS

The electronic module is not designed to be repaired in the field. If a problem should develop, first carefully check for proper wiring and switch setting. If it is determined that the problem is caused by an electronic defect, the device must be returned to the factory for repair.

NOTE

When replacing an electronic module, be sure that the rocker switches of the replacement are the same as the original. Remove power before removing the housing cover from the detector or plugging in the replacement module.

DEVICE REPAIR AND RETURN

Prior to returning devices or components, contact the nearest local Detector Electronics office so that a Service Order number can be assigned. A written statement describing the malfunction must accompany the returned device or component to expedite finding the cause of the failure.

Pack the unit or component properly. Use sufficient packing material in addition to an anti-static bag or aluminum-backed cardboard as protection from electrostatic discharge.

Return all equipment transportation prepaid to the factory in Minneapolis.

ORDERING INFORMATION

When ordering, please specify:

U7602E Unitized UV Flame Detector

ACCESSORIES

Part Number	Description
004404-005	Swivel Mount
W8066	Portable UV Test Lamp
U7656	Hand-held UV Monitor

REPLACEMENT PARTS

Part Number	Description
003240-202	DE1888B2 Module
003240-220	DE1888U2 Module*
006605-001	Electronic Module without 4 to 20 ma output
006605-002	Electronic Module with 4 to 20 ma output
002507-001	Window cleaner kit
002519-001	o-ring
107427-040	O-Ring (large)
107427-004	O-Ring (small)

*High speed system only, zero time delay.

APPENDIX A

FACTORY MUTUAL RESEARCH (FMR) APPROVAL DESCRIPTION

(THE FOLLOWING ITEMS, FUNCTIONS AND OPTIONS DESCRIBE THE FMR APPROVAL)

Model U7602E Series UV Flame Detector

- Explosion-proof for Class I, Div. 1, Groups B, C and D Hazardous (Classified) Locations per FM 3615.

Standard Temperature Version

- Explosion-proof for Class I, Div. 1, Groups B, C and D Hazardous (Classified) Locations per FM 3615.
- Nonincendive for Class I, Div. 2, Groups A, B, C and D (T3C); Class II/III, Div. 2, Groups F and G (T3C) Hazardous (Classified) Locations per FM 3611.
- Dust-ignition proof for Class II/III, Div. 1, Groups E, F and G Hazardous (Classified) Locations per FM 3615.
- Enclosure rating NEMA/Type 4X per NEMA 250.
- Ambient Temperature Limits: -40°F to +167°F (-40°C to +75°C).
- Automatic Fire Alarm Signaling Performance verified per FM 3260.

High Temperature Version

- Explosion-proof for Class I, Div. 1, Groups B, C and D Hazardous (Classified) Locations per FM 3615.
- Nonincendive for Class I, Div. 2, Groups A, B, C and D (T3); Class II/III, Div. 2, Groups F and G (T3) Hazardous (Classified) Locations per FM 3611.
- Dust-ignition proof for Class II/III, Div. 1, Groups E, F and G Hazardous (Classified) Locations per FM 3615.
- Enclosure rating NEMA/Type 4X per NEMA 250.
- Ambient Temperature Limits: -40°F to +257°F (-40°C to +125°C).
- Automatic Fire Alarm Signaling Performance verified per FM 3260.

RESPONSE CHARACTERISTICS—

A Model U7602E with B2 Module was verified to comply with the following performance criteria:

Standard Mode, Very High Sensitivity (10 cps), Zero Time Delay			
Fuel	Size	Distance	Response Time
Gasoline	1 ft x 1 ft (0.3 m x 0.3 m)	90 ft (27.4 m)	<1 sec.
Diesel	1 ft x 1 ft (0.3 m x 0.3 m)	65 ft (19.8 m)	<1 sec.
Methane	30 inch plume	80 ft (24.4 m)	<1 sec.

NOTE: All fuels at 20°C ±2°C with response timed from fuel ignition.

Standard Mode, High Sensitivity (25 cps), Medium Arc Rejection Mode, Zero Time Delay								
Fuel	Size	On Axis		Off Axis				
		Distance Ft. (M)	Response Sec.	Distance Ft. (M)	Horizontal Response, Sec.		Vertical Response, Sec.	
					+45°	-45°	+45°	-45°
Methane	30" Plume	75 (22.5)	1.2	37.5 (11.2)	1.0	1.7	0.7	1.0
Methanol	1 Sq. Ft. (0.09 Sq. M)	30 (9)	2.3	15 (4.5)	1.2	0.9	1.0	2.5
Gasoline	1 Sq. Ft. (0.09 Sq. M)	65 (19.5)	0.8	32.5 (9.7)	0.8	0.9	0.6	0.8
Heptane	1 Sq. Ft. (0.09 Sq. M)	50 (15)	1.2	25 (7.5)	1.0	3.3	0.9	0.8

Atomized Fuel Fires				
Fuel	Size	Distance Ft. (M)	Response Time, Sec. (Standard Mode, Zero Time Delay)	
			25 cps	50 cps
			Methanol	Flow Rate 10 CC per Sec.
Isopropanol	Flow Rate 10 CC per Sec.	50 (15)	.04	.07
Acetone	Flow Rate 10 CC per Sec.	50 (15)	.04	.08
Heptane	Flow Rate 10 CC per Sec.	50 (15)	.02	.05

HIGH SPEED RESPONSE—

12 millisecond response time to a saturating source (UV input).

ANGLE OF VIEW—

-45 to +45 degrees off centerline in vertical and horizontal planes (methane).

UV ARC REJECTION—

Electrical Arcs.

FALSE ALARM IMMUNITY—

- Direct sunlight.
- Reflected sunlight.
- 75 watt Phillips Far Spot incandescent lamp at 3 feet (1 m).
- 100 watt incandescent light bulb (rough service) at 3 feet (1 m).
- 300 watt incandescent light with clear lens at 3 feet (1 m).
- 250 watt infrared heat lamp at 3 feet (1 m).
- Two 34 watt fluorescent light tubes at 3 feet (1 m).

- 500 watt Phillips Quartz halogen light at 3 feet (1 m).
- Radiation produced by a 6 KW infrared electric heater at 3 feet (1 m).
- Vibration immunity for vertical displacement of 0.02 inch (0.5 mm) at a frequency of 10 to 30 Hz for 4 hours.
- Radio frequency interference (RFI) immunity at 12 inches to 155 Mhz and 450 MHz with radiation power levels of 5.0 W.
- Surge transient immunity for peak levels of 100, 500, 1000, 1500, and 2400 vdc as delivered into a 200 ohm load.

MOUNTING—

Q9001L swivel mount.

APPENDIX B

U7602E WITH THE APOLLO MODULE

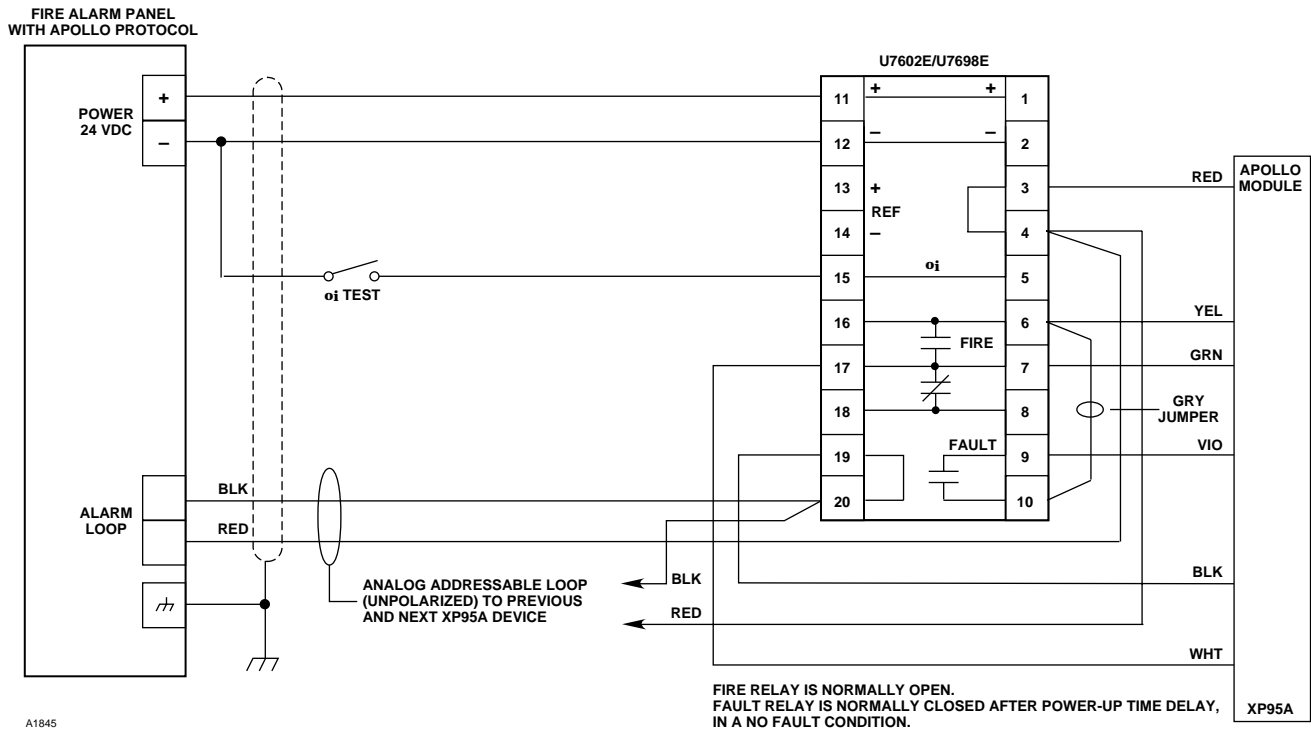

U7602E/U7698E Detector/Apollo Module Style D (Class "A") Wiring Diagram

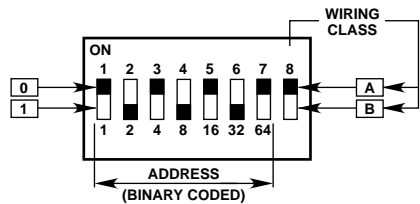

SWITCH DIAGRAM ABOVE SHOWS AN ADDRESS OF 0101010 = 42 CLASS "A" WIRING

A1846

SWITCH SETTING: THE ADDRESS NUMBER IS BINARY ENCODED WITH ROCKER SWITCH NO. 1 BEING THE LEAST SIGNIFICANT BIT. EACH ROCKER SWITCH HAS A SPECIFIC BINARY VALUE. THE ADDRESS IS EQUAL TO THE ADDED VALUE OF ALL CLOSED ROCKER SWITCHES. ALL OPEN SWITCHES ARE IGNORED. SWITCH NO. 8 SELECTS CLASS A OR B WIRING.

NOTES

1. WIRING SHOWN IS STYLE D, CLASS A. STYLE B, CLASS B NOT SHOWN AND NOT RECOMMENDED.
2. FOLLOW LOCAL ELECTRICAL CODE WHEN INSTALLING EQUIPMENT.

Apollo Module DIP Switch Setting

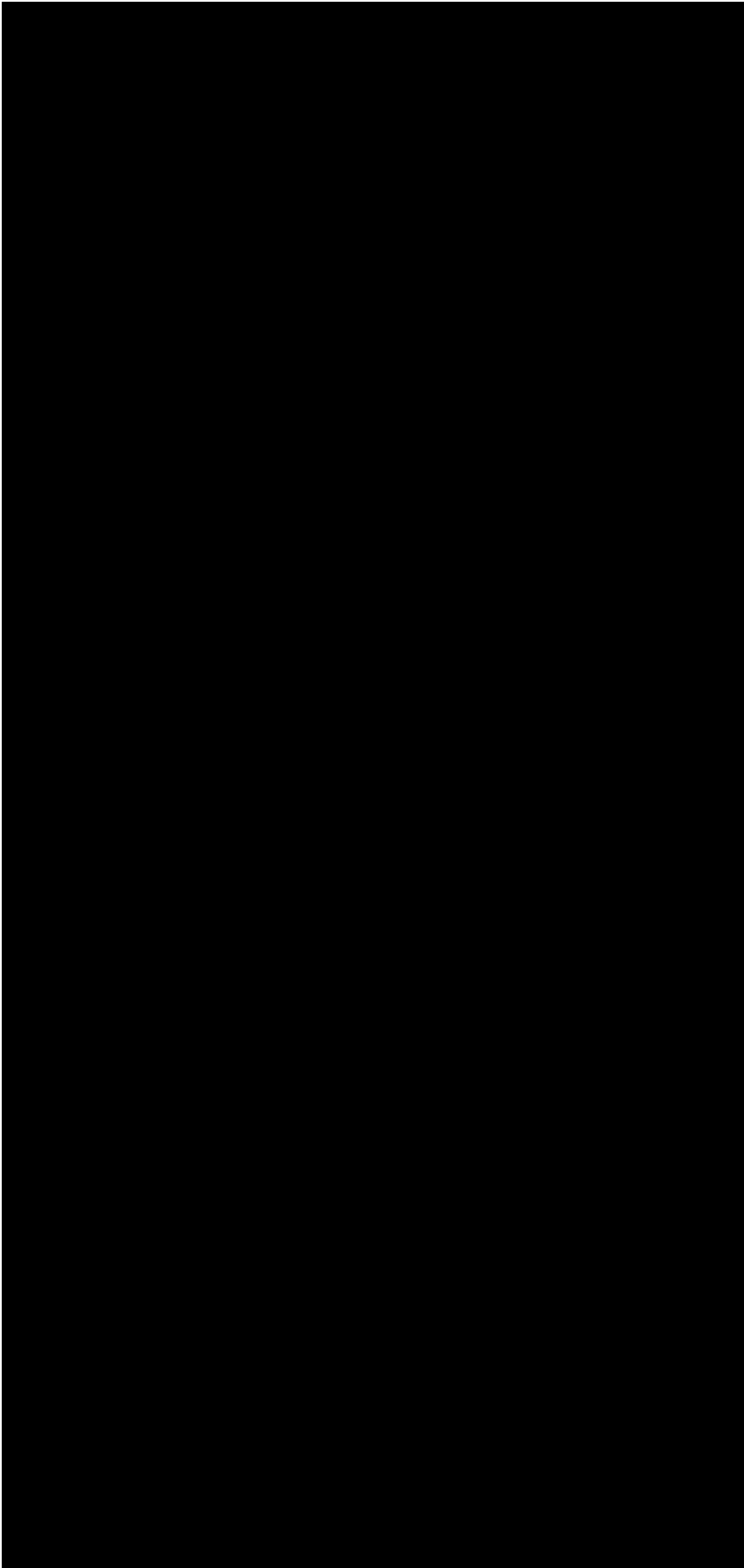

Printed in USA

Detector Electronics Corporation
6901 West 110th Street • Minneapolis, Minnesota 55438 USA
Tel: 612.941.5665 or 800.765.3473 • Fax: 612.829.8750